

QTY.	PART NUMBER
1	ROTARY-01-CYLINDER-1
1	ROTARY-02-CYLINDER COVER-1
1	ROTARY-03-CYLINDER COVER-2
1	ROTARY-04-ROTARY DISPLACER
1	ROTARY-05-BALANCER
1	ROTARY-06-CRANK DISC
1	ROTARY-07-CYLINDER COVER-3
1	ROTARY-08-CYLINDER-2
1	ROTARY-09-POWER PISTON
1	ROTARY-10-CONNECTING ROD
1	ROTARY-11-PISTON PIN
1	ROTARY-12-SHAFT-1
1	ROTARY-13-SHAFT-2
1	ROTARY-14-SHAFT SEAL
1	ROTARY-15-TUBE
1	ROTARY-16-SPACER
2	ROTARY-17-ROLLER BEARING
1	ROTARY-18-CRANK PIN
1	ROTARY-M3x2 PAN HEAD SCREW
2	ROTARY-M3x17 C-SINK SCREW
10	ROTARY-M3x18 PAN HEAD SCREW

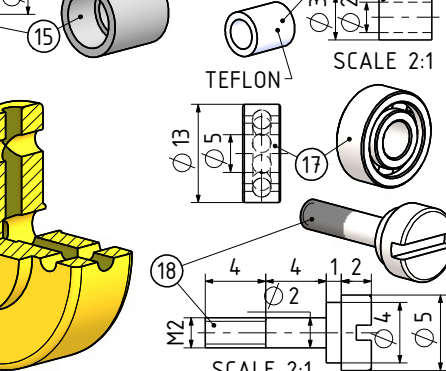
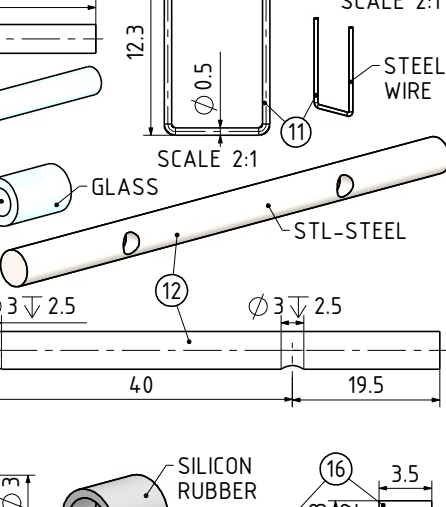
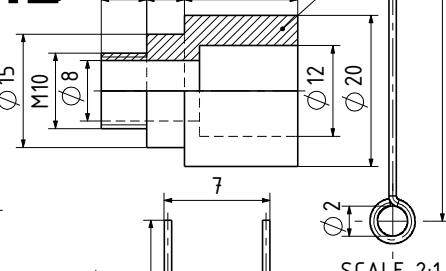
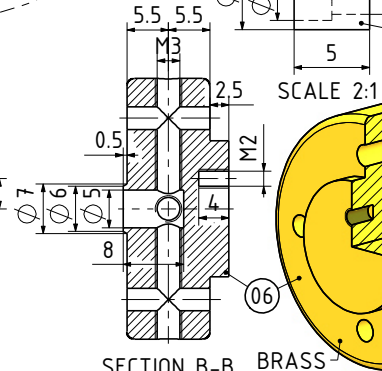
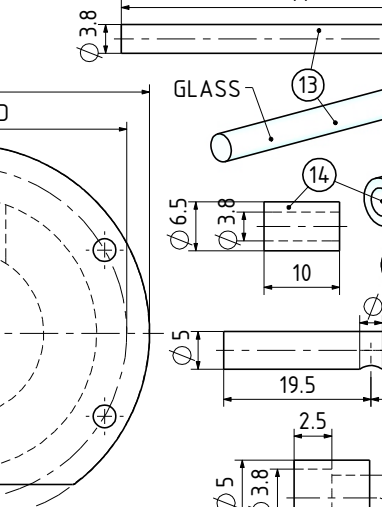
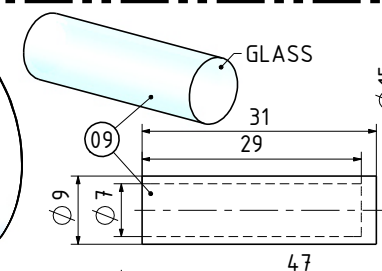
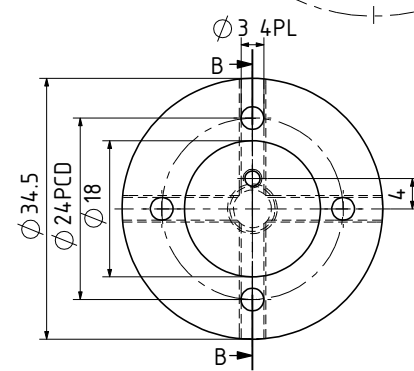
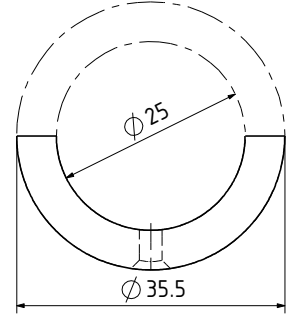
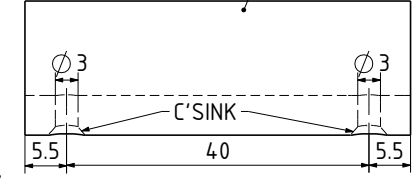
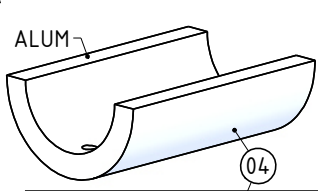
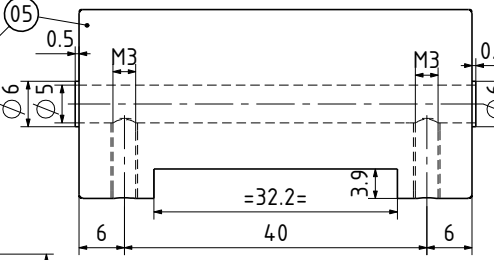
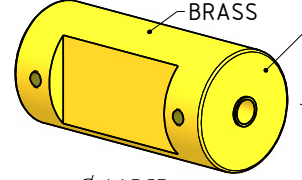
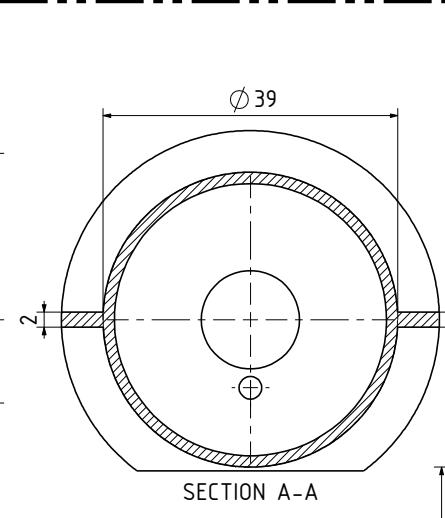
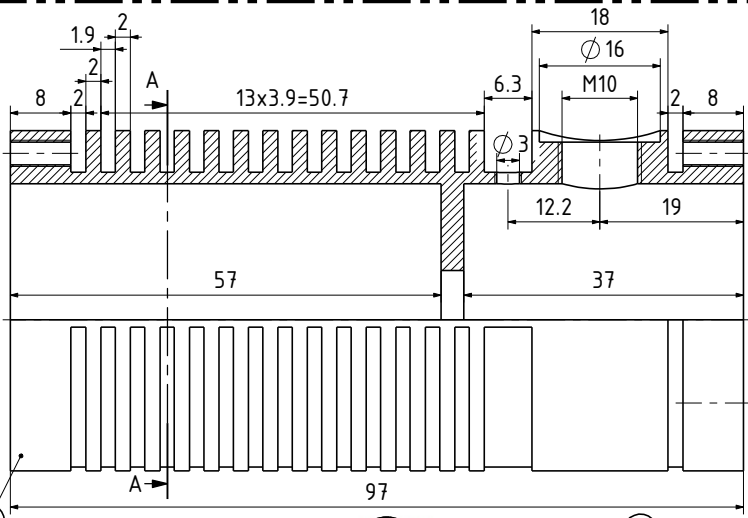
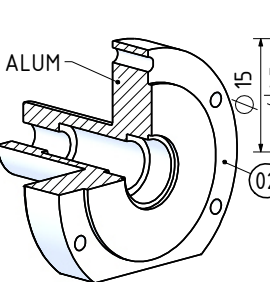
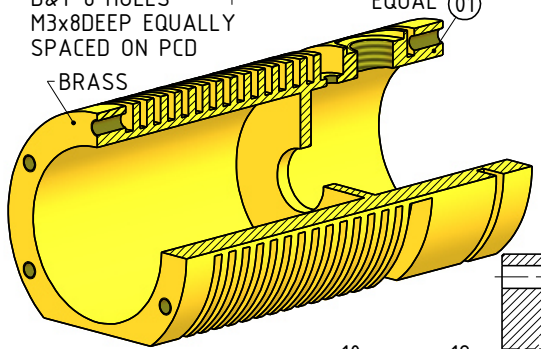
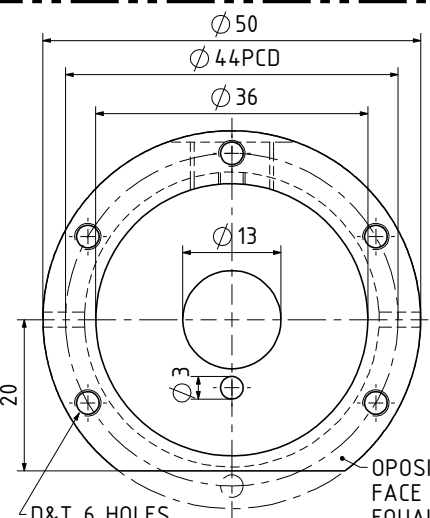
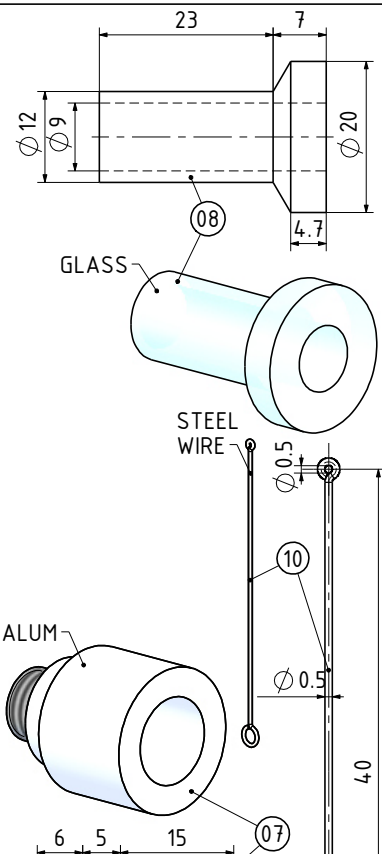

NOTES: THIS ENGINE WAS DESIGNED AND BUILT BY MR. KOICHI HIRATA (1990). FOR MORE INFORMATION GO TO: WWW.BEKKOAME.NE.JP/

TITLE
ROTARY STIRLING ENGINE

DRAWING CONTENTS
GENERAL ARRANGEMENT

PROJECT No 05A-11-00
JDW DRAUGHTING SERVICES
 J.A.M. DE WAAL 12 BRIGHTWELL STREET PAPA KURA 2110.
 NEW ZEALAND. PHONE: 0064 09 2988815. MOB: 0211791000
 E-MAIL: dewaal@xtra.co.nz.

PROJECTION
JDWDS
 DATE
 JULY-2015
 SHEET: 01 OF 01

MODEL SCALE: 1:1
 DWG SCALE: 1:1 @A3 OR AS SHOWN
 Copyright © J.A.M. DE WAAL PAPA KURA NZ
A3 No: 05A-11-00-SHT01

DRAWINGS ARE FOR PERSONAL USE ONLY NOT FOR COMMERCIAL PURPOSES