

Here are some details to help you

Create Your Own Designs

Throughout the development of these engine designs, there have been certain details that were reused. They worked, they were easy to build and they were handy. They also simplified the preparation of the text for each article.

Although you see them through this book, we have grouped them here for those who might want to design their

own engines, using these references and details.

There are the Symbols which indicate a condition that should be met at a certain point. There are two different Cylinders, a Steam Chest, Steam Chest Cover, Valve Plate, a Valve and Valve Nut. There is an Inboard Head and an Outboard Head, an Eccentric, two Pack Nuts, and a Fly-

wheel which was used several times.

Check them over before you begin work on a new project and apply any of these parts to any engine you decide to build.

Once you are familiar with these, their relationship to the engine you envision will be clear and you can proceed in your project with utmost confidence.

SYMBOLS		
Ⓒ	CLOSE FIT	Close clearance between two parts. A close but free-running fit with no shake. Make one surface and machine the other to fit.
Ⓔ	SMOOTH	A fine polished surface for minimum wear.
Ⓕ	FLAT	Ground flat with very fine emery paper on a surface plate or plate glass for a tight metal-to-metal sliding seal.
Ⓑ	BRAZE OR SOLDER	Silver solder in some cases; up to you and your equipment. Most soldering in these designs has been with 430° type solder.
⒫	PRESS FIT OR LOCTITE	Your choice. Loctite has been quite successful. Follow Loctite's instructions.
Ⓖ	LOCTITE	Loctite recommended.
MTP	MODEL TAPER PIPE	Tapered pipe thread for model makers.
—	PACKING	Packing is mentioned in the text on some engines and stuffing boxes are shown. In all cases, use your favorite packing which can range from common cotton twine to graphited asbestos. Some models depend on only a close fit and a bit of lube to seal at low pressures.
<p>The small symbols inside the circles shown at various surfaces and dimensions indicate a condition that that area should meet. They reduce the amount of data on the drawing and you will soon learn their meaning.</p>		

BASIC CYLINDER

TYPE M

For those who like to work up their own engine ideas.
 Material: hard aluminum, brass or fine-grained cast iron.
 1/2" bore, 1" stroke using 1/4" wide piston.

Make an accurate 1" x 1" x 1-3/8" block. Lay out all the centers and lines on all six faces. Note that the bore centerline is 15/32" from the faces at one corner. Complete all drilling and tapping while the block is square and easy to hold. Mill 1/16" ports. The head bolt holes can be made using the heads as jigs after the bore is made. Proceed with **Step 1**, chucking in the 4-jaw using a center test indicator. Bore 1/2" and turn the 15/16" diameter. Reverse in the chuck and turn the second end as in **Step 2**. Make a milling setup and complete **Steps 3, 4 and 5**. Rounding as in **Step 6** is optional. This will be covered if lagging is used. This type has its own foot for mounting on a base.

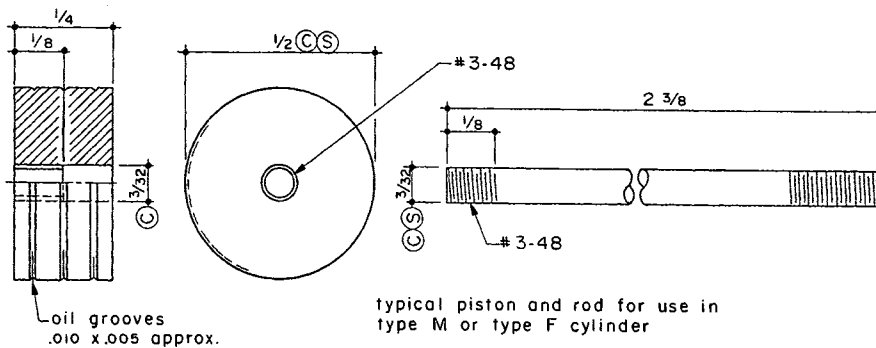
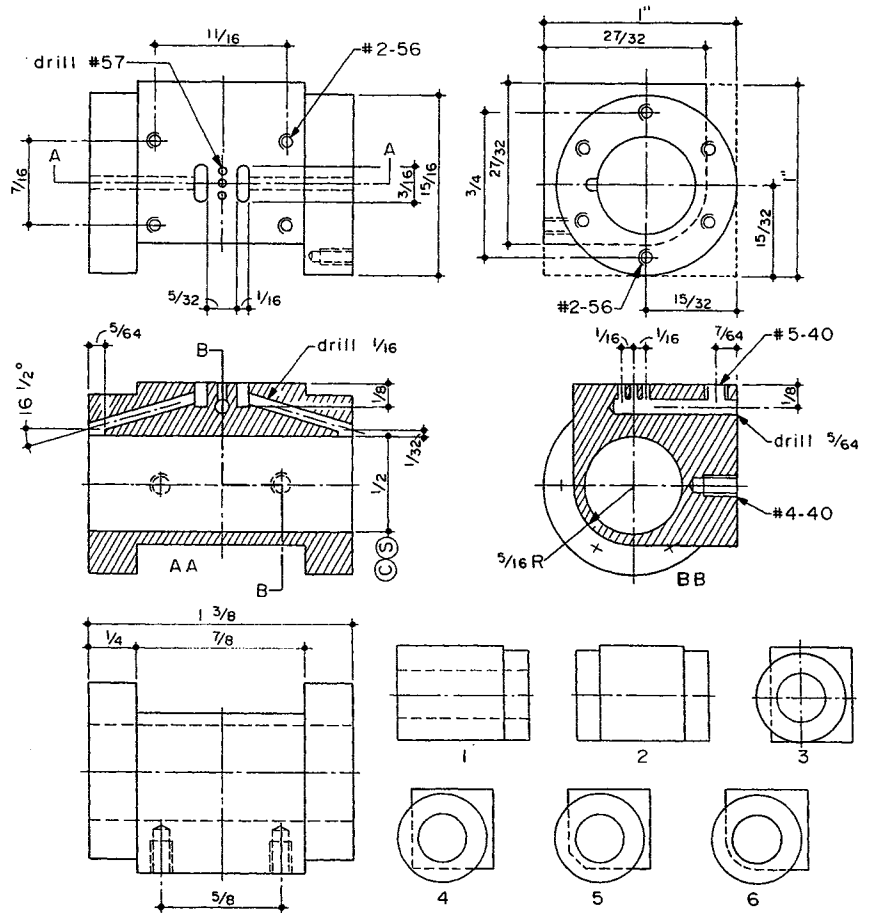

**TYPICAL PISTON AND ROD
FOR USE IN TYPE M OR
TYPE F CYLINDER**

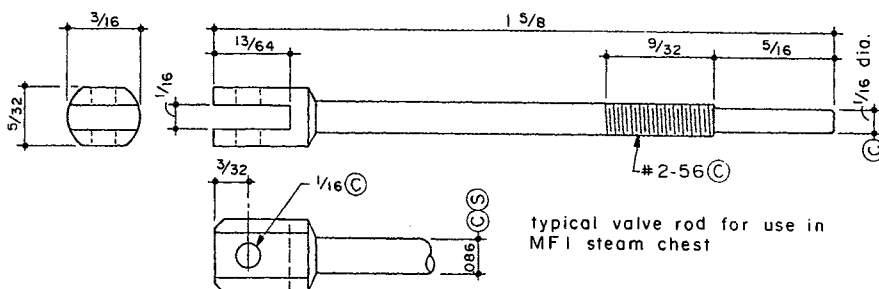

**TYPICAL VALVE ROD
FOR USE IN
MFI STEAM CHEST**

BASIC CYLINDER

TYPE F

Material: hard aluminum, brass or fine-grained cast iron

1/2" bore, 1" stroke using 1/4" wide piston

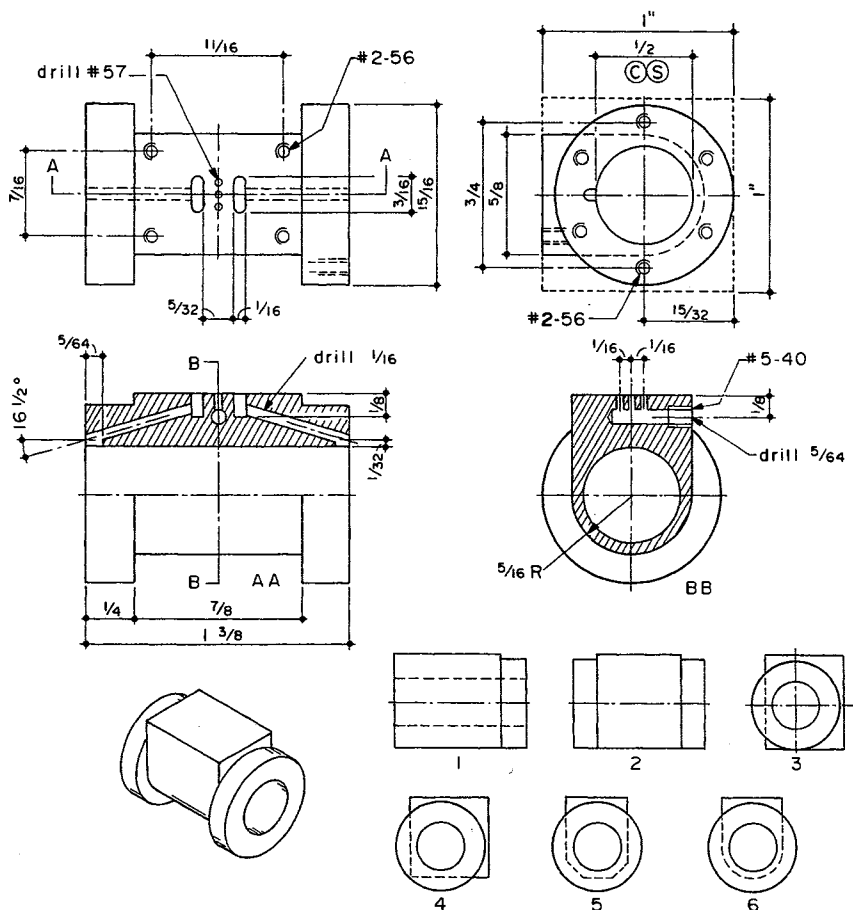

Make an accurate 1" x 1" x 1-3/8" block. Lay out all centers and lines on all six faces. Note that the bore is centered one way on the 1" square and 15/32" from one of the other faces. Complete all the drilling and tapping while the piece is square and easy to hold. Mill 1/16" ports. The Head bolt holes can be made using the Heads as jigs after the center is bored. Note: keep the bolt pattern parallel with the valve surface so the feet, when attached, will fit down on the base. Proceed with **Step 1** in the 4-jaw, centering on the bore using a center test indicator. Next, make the 1/2" bore and turn the 15/16" diameter. Reverse in the chuck and turn the second end as in **Step 2**. Make a milling setup and complete **Steps 3, 4 and 5**. Rounding as in **Step 6** is optional. This type of Cylinder can be flange-mounted or vertical on a table with screws up through the table and head.

The following parts fit Type M and Type F Cylinders

STEAM CHEST MF1

Material: aluminum or brass

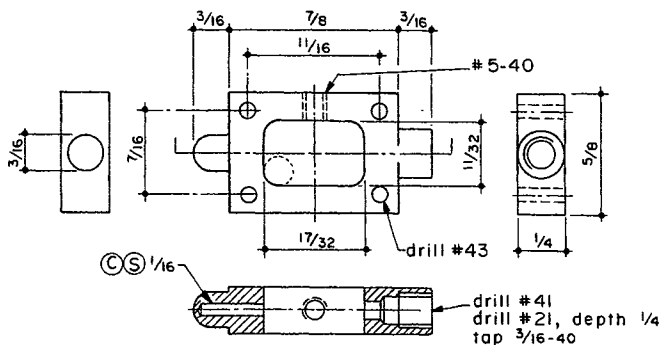

The Steam Chest is first laid out completely on an accurate 1/4" x 5/8" x 1-1/4" block. Center in the 4-jaw using a center test indicator to turn each end and bore for the Valve Rod and tap for the Pack Nut. Use drilled holes to form the radius in the square center hole. Saw and file to shape.

STEAM CHEST COVER MF2

Material: aluminum or brass

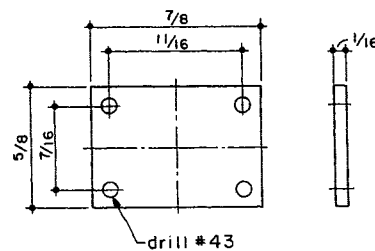

Simple layout and drilling. The cover must be reasonably flat.

VALVE PLATE MF3

Material: brass

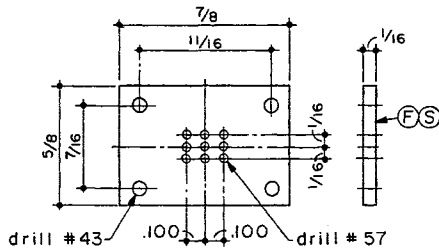

The face the Valve slides on must be very flat and smooth for a metal-to-metal sliding seal.

VALVE MF4

Material: brass

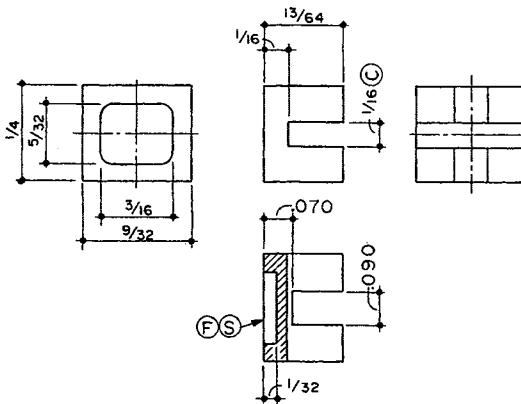

Make the Valve of 1/4" x 5/16" or 5/16" x 5/16" brass rod an inch or two long. Mount it in the cross-slide milling attachment and machine to 1/4" x 9/32" for about 5/16". While in the mill, make the 1/16" and .090" slots. Use a slitting saw and cut to a few thousandths over 13/64". Mount in the vise and mill the 1/32" recess with a 1/16" end mill. Dress the face down on fine emery paper on a surface plate to the 1/16" dimension at the 1/16" groove. Try for freedom on this part so it will just barely float on the seat as steam pressure holds it down. At the same time avoid sloppiness at the Valve nut.

VALVE NUT MF5

Material: brass

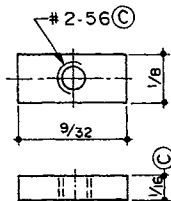

Make this part a close free fit in the Valve slot. Avoid sloppy thread for the Valve Rod.

INBOARD HEAD MF6

Material: aluminum or brass

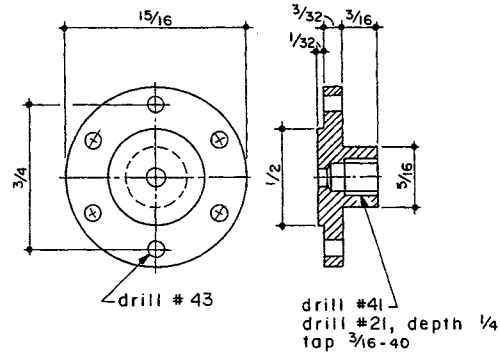

Chuck a short piece of 1" bar stock in the 3-jaw and turn the O.D. and hub. Bore for the Shaft. Enlarge and thread for the Pack Nut. Part off at about 5/16" long and reverse in the chuck, gripping on the hub. Face and form the dowel a few thousandths under 1/2". Scribe the bolt circle, pace off six even spaces and drill for the bolts.

OUTBOARD HEAD MF7

Material: aluminum or brass

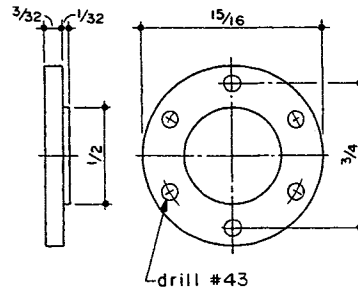

Follow the INBOARD HEAD instructions, omitting the hub. Turn the dowel on the first chucking. Scribe the bolt circle. A fine pass with the parting tool before final parting may give you a good enough finish, avoiding a second chucking. Dress down the outside face on a wide fine file and finish with fine emery on a surface plate.

ECCENTRIC MF8

Material: steel
 (.100" throw, .050" offset)

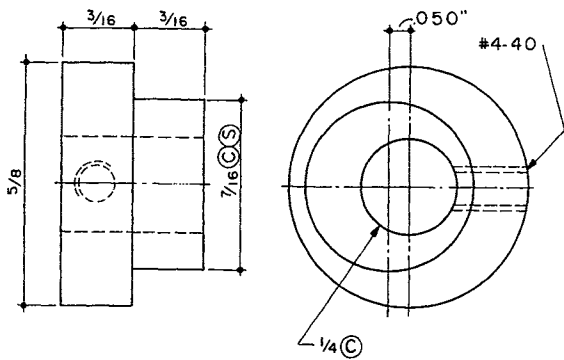

Chuck 5/8" diameter stock in the 4-jaw, brighten the O.D. and bore 1/4". Offset .050" and turn the 7/16" diameter. One way is to mount a square-ended bar in the tool post and bring it up against the stock. Zero the cross-slide collar and turn the chuck so two jaws are horizontal. Ease off the vertical jaws slightly and back up the rear jaw about 1/16". Push the stock back, using the front jaw. Advance the cross-slide .050" and ease the stock back against the bar using the rear jaw. Snug up all jaws. Now, when the high spot just kisses the bar and the chuck is rotated 180°, a .100" diameter rod should just pass between the bar and the low spot. You are now ready to turn a smooth 7/16" diameter. Spot the setscrew on the centerline through the bore and the offset. The hex key helps when timing the Valve.

PACKNUT MF9

For 3/32" rod
 Material: aluminum or brass

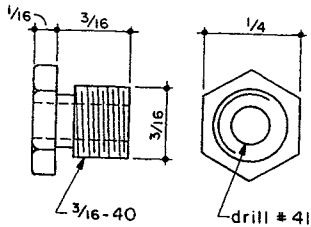

PACKNUT MF10

For .086" rod
 Material: aluminum or brass

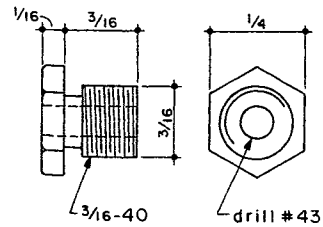

FLYWHEEL CONSTRUCTION MF11

Material: any metal

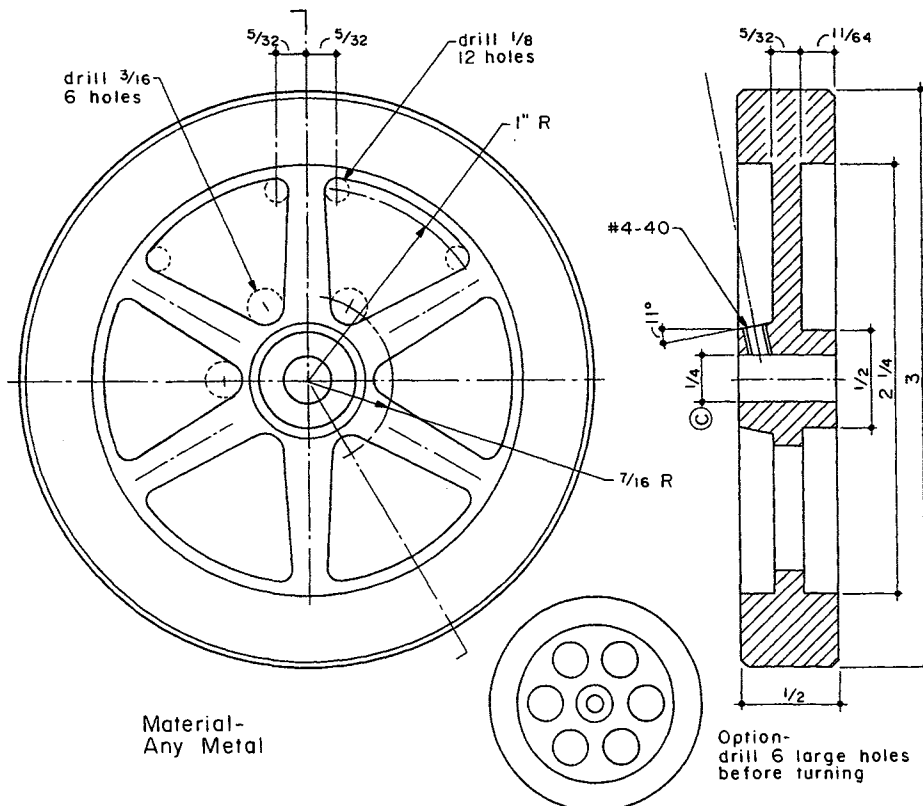

Material-
 Any Metal

Option-
 drill 6 large holes
 before turning

Odds & Ends for Beginners

A SIMPLE STORAGE SYSTEM

This is probably just a notion, but I like a simple storage system used for small screw assortments. Clear plastic hinged boxes about 3" x 4" x 1" are used. The screw size is labeled inside the see-through cover. The four main sizes are 2-56, 3-48, 4-40 and 5-40. Each box has the standard tap, die and tap-drill used for its contents. Also a dull tap was cut back, the end ground square and a one-thread lead added, thus forming a bottoming tap for shallow holes. The screws in each box are all of that thread size found in the entire shop, round, fillister, flat head, new, old, steel, brass, etc.

Radio Shack is a fair source for these sizes. Old TV and radio sets are sometimes a good source of salvage screws. It puts all related material together and reduces error and hunting time.

HEAD BAND MAGNIFIER

When you get as old as I am, your eyes need help reading the fine graduations on verniers, graduated collars, scribed layouts, etc. The greatest help has been a head band magnifier. Jewelers and many other professionals use them, so don't let it bother you to be seen using this help.

One big advantage is, it frees both hands to manipulate the part and the tools. I have made a layout of a bolt pattern on a cylinder and another on a cover and brought them together and all the screws entered through both parts. This layout, of course, was made on a surface plate, using a vernier height gauge, which produces very fine layout lines. The clearance holes in the cover were about .008" over the actual bolt diameter.

Using the magnifier and a sharp scribe, a tiny prick can be made where the layout lines cross. A sharp prick punch then picks up these prick marks and next the centerpunch. It takes a bit of patience but it is surprising close.

This method may require marking the parts and always assembling in

the position in which it was drilled. It doesn't mean, however, that you can't use the cover as a jig.

PRE-JIGGING

Many irregular-shaped parts are hard to hold in ordinary vises, etc., so pre-jigging is a solution. The part may be shimmed and bolted to a block of metal and, from then on, layout and holding are related to this block. The block allows the part to be held in a vise or bolted to an angle plate or face plate. It is also the means of gripping in a 4-jaw chuck. This block may require milling to "nest" the part. Tapped holes may be needed in a hidden face of the part to be worked so it can be bolted to this block. Maybe one face of the part lends itself to filing a flat and that surface, then, soldered to a plate or block which can be gripped in a vise, etc.; later heating to free the solder.

When you hold a part in a V-block which has a clamp, you are doing about the same thing.

Sometimes an irregular-shaped part can be blocked and shimmed in a small tool makers' vise and this vise held in still another vise squarely or at an angle to suit. This small vise can be fastened to face plates or angle plates for odd milling and drilling conditions.

A very slender or fragile part can be soldered to a stronger piece of metal and, when done, heated to free the solder.

Along this line of thinking, a method was once described by Dr. James Senft to drill a part in a modelmakers lathe. He *taped* the part to a face plate! Very clever, and it shows there is no limit to the ideas you can come up with to do odd jobs.

Pre-jigging is actually a jig within a jig. You might say a part was held in a jig which was then held in the drilling or milling jig.

PIPE CLEANERS

It's a good idea to keep pipe cleaners handy in your shop area. They

will wipe the chips and cutting oil out of drilled holes or grooves. They can reach into corners to clean or apply oil or other fluids.

Most layout dye containers have a brush in the cover which often is too large or applies too much dye. Touch a pipe cleaner to the brush and transfer a light dab to your small parts. Snip off the end of the cleaner and it is ready for some other job.

The same applies to soldering acid flux. By cutting off the end, it is reusable and less apt to rust tools and parts it might touch.

MEASURING

If you wish to work to close limits, develop good measuring habits.

Measure by eye with a scale and then check it with a mike, even though the tolerance isn't that close. It is good practice.

Measure parts with a vernier caliper and then with a mike. If they don't come out alike, use a magnifying glass and study the vernier scale to see if you would now read it differently. In other words, use the mike and vernier a lot.

When you are approaching the final cut, you always make lighter cuts and measure often.

Somewhat the same applies to the square. The tolerance is generous but try it for squareness anyway. It will take a bit of time but it tells you how good your machine is and how well you are doing on your lathe or milling machine.

My father was a millwright and carpenter. When I was a kid, making bird houses, etc., he said to me, "Make all the cuts to size and square. When you put it together, it will be square." A bit simple and homey but it applies to machine shop, too.

If it doesn't come out square, there may be a small chip clamped under one corner, or you didn't get the vise squared up on the machine. Maybe the keys in the vise are too sloppy in the T-slots. Use a junior indicator and check to see if the vise jaws are parallel to the table travel. If you are

doing repeat operations, you always brush out the holding device before inserting the next part.

LAYOUT HINT

A very handy item in your shop is a vise that is square in all directions. Square, that is, so an object held in the jaws can be squared up with a face of the vise and the vise used in the normal position or on its side or on its end.

This item will show a quick way to center a drill on a round part:

Often you wish to drill through the center of a rod and struggle to locate the punch mark centered between the jaws.

Apply layout dye to the surface you wish to drill. Scribe the cross lines for locating the holes lengthwise on the part as shown at **A**. Mount in the vise as shown at **B** and lightly slide the square along so it will just make a mark in the dye, crossing the lines **A**. Use a magnifying glass and prick punch on the crossed lines; centerpunch, and the part is ready, mounted and punched for drilling. The drilled hole will be very close to rod center.

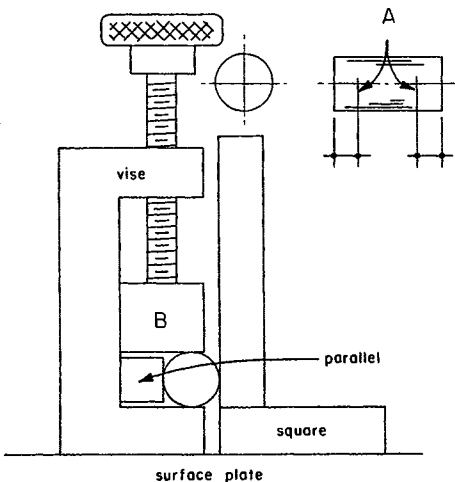

CUTTING OIL BRUSH

Cut the two outside rows of bristles and the plastic off a 3-row tooth brush, leaving just one row of bristles. You now have a handy way of applying cutting oil to a parting cut.

Load the bristles with cutting oil and hold in the groove. It will continue to supply oil to the cut for some time. Keep this brush, loaded with oil, handy on any cutting job on steel. A light pass over the surface makes for better cutting.

While on the subject of cutting oil,

we might mention that newcomers to machine shop can obtain cutting oil at most hardware stores. Ask for "pipe thread cutting oil" in the plumbing department. It is dark colored and looks messy but it does a good job. Some people are sensitive to this oil and may have to avoid it.

Another source of cutting oil I have been using for brass and aluminum is a popular liquid for loosening nuts on machinery, *Liquid Wrench*. Some handbooks mention kerosene for these metals. This stuff appears to me as deodorized kerosene. It is already in a spout can for easy application.

CUTTING COMPOUND

The next time you work aluminum, try Isopropyl alcohol (rubbing alcohol) as a cutting compound. My son works in a factory that makes relays, solenoids, etc. They often make test fixtures and prototype models to try in test cars. This alcohol is used out in the factory so it was tried for working aluminum. It carries heat away, there is no build-up on the cutting tool and it is inexpensive and clean. A hypodermic syringe is handy for this. Cut off the sharp point.

The alcohol will wash off surrounding layout dye. So, if you have further use for the dye and layout marks, a bit of care is called for to reduce the loss of the dye. Perhaps the sequence of operation can be changed to reduce this problem.

SOURCE FOR ROUND RODS

A good source of 1/16" and 1/8" round rods is Sears welding supply department. These rods are steel (copper coated) and bronze. The diameters are quite consistent, .062" and .124" for their entire length and straight enough to be used for small shafting applications. Of course, "shafting" this size means very small models, but you will find many uses for these in your shop. They polish up nicely and solder easy. Welding supply shops have more sizes and longer rods.

TIN-PLATED STEEL

If you have need for a small piece of fine tin-plated steel, try the containers of a popular vegetable shortening. Cut off the ends carefully to avoid a crinkled edge and flatten. It solders beautifully.

MARKING PENCIL

A handy item to have in the shop is a red china pencil or a grease pencil, one that will mark on glass or a polished surface. When you wish to return to a certain setting of the cross slide, note the collar reading and mark it with chalk on the compound body or some nearby flat surface. At the same time, use a red china or grease pencil to mark the collar at this setting. It is like a flag to catch your eye when returning to that setting. You can remember times when a mark or dimension would have been a handy reminder in later operations. It is not hard to rub out the pencil marks on smooth surfaces when the project is completed.

STARTING A JOB

When you are about to make a part for a model, sketch that part completely on a sheet of plain or cross-sectional paper. Make every line and dimension so you can work from it at the bench. This keeps your original print or magazine in clean condition.

The greatest advantage, however, is that you become thoroughly acquainted with the part and every little detail will show up. By checking your sketch against the original, you become very familiar with all details. This helps you with related parts.

If you use a vernier height gauge and surface plate to make layouts, this gives you a place to red-pencil the vernier readings, make side notes, etc. By using this procedure, you will become quite proficient at sketching which is always handy if you see something at a show you wish to pursue further. It is like writing a name or date to impress it better on your memory.

A ROCKING CHAIR

I am not a young man and, after a couple hours at the bench or lathe, I like to sit in one of two old rocking chairs I keep in my shop.

After a short rest studying the part or print (maybe sometimes dozing), I feel like going on with a project.

These chairs also serve when I have visitors, at which time I drop everything I am doing as the chatter may be distracting and could cause mistakes or accidents.

The best thing to do is to start the air compressor or fire up a boiler and

show off some models and talk shop.

It requires a very special visitor to avoid distraction. He knows what you are doing and when to speak and how to lend a hand. He is fun to have around because he talks your language. It is also fun to visit his shop.

Maybe the best thing to do is to avoid anything too comfortable for visitors.

SUPPLIERS' CATALOGS

Many complain that suppliers charge too much for their catalogs. This comes about because people send for them and often never buy anything. They use them as dream books or wishing books to get ideas or just simply to get something in the mail.

Now, that is exactly what I like to do, so I have paid the price to several of the best dealers. I like to know what is available and compare prices, etc., and study them to get ideas.

A well-illustrated catalog costs money. The price of a catalog is about equal to the cost of a couple of paperbacks which are eventually thrown away or soon given away.

If you are a model nut like I am, you will use it for years, even save the old one when a new one is issued. I have one that was issued six years ago and has been patched up a couple of times. I feel I am less obligated to buy if I paid their price for the catalog. However, I do buy from most of them, though not in as large quantities as they would like.

Questions are asked by readers that would have been answered if they were acquainted with these catalogs. I consider some well-written catalogs as a small textbook of a sort and have learned quite a bit from them.

A CLEAN SHOP

In **MODELTEC** Magazine for June 1985, an item in the **Dots & Dashes** column contained a "puzzler" by David Farmer. It was a message written out in dots and dashes and it turned out to read, "How does Elmer Verburg keep his lathe so dog-gone clean?" This would be my reply.

Back in 1980 or 1981, Miles Snyder ran a series of articles on photography which I read and tried to use some of his methods and suggestions.

One of the articles dealt with the subject of "Photos Around the Shop" in which he stated, "Clean up the area you're going to photograph. Bring out the shop brush, get most of

the chips off the lathe and sweep them into a dust pan. Then unlimber the Shop-Vac."

Now, I still need a lot of practice to make good photos but I hope my efforts are helping get across some of the steps in making models. I chose the clean setup, but it is hard to match the photos made by an expert like Miles.

If you are demonstrating an operation, the visitor will see the chips and all the clamps, bits of metal shims, and odd screws that got you by in a one-time setup. Is this more natural? Should this be photographed?

This gets into an interesting subject. We all like to visit other modeler's shops. Is it more fun to visit, say, a woodworker's shop and find a vast confusion of stock and trimmings leaning, stacked and underfoot, well-covered with fine sawdust — and here and there a half-finished or abandoned project and some mysterious looking tool or jig that gets your curiosity worked up? You can't walk through it without getting dust spots on that dark blue suit and the whole thing is in orderly confusion so that only the owner can lay his hands on anything he needs.

Or is it more fun to visit a "spit-and-polish" shop? They both have interesting points. Is one a jolly fellow who always welcomes you and can dig out interesting projects to talk about, or perhaps is the shop a hobby and not what the shop can produce?

The same applies to a machine shop with metal chips, oil, bits of rust and dust. I consider my shop as a happy medium since it is in the house and you know I have to be careful about tracking chips around about. A visitor in a slicked-up shop may feel out of place though he can most likely solve problems quickly and as well with his own methods. He can work wonders with an old restored lathe.

BUILD A BOX BASE FOR YOUR MODELMAKER'S LATHE

There are some simple modifications you can make to a modelmaker's lathe, such as a Unimat, which makes it easier to use.

Start with a box base made from thick material which gives some weight and body as well as providing storage space for attachments.

The outside dimensions of the box base for my modelmaker's lathe are 17" long, 9" wide and 5-1/4" high. You can start with those dimensions and

modify them to suit your equipment.

The corner joints are rabbeted, glued and nailed. The drawer front is 3/4" thick and the sides and back of the drawer are 1/2" thick. The drawer bottom is 1/8" hardboard, set in a groove. Squares of rubber were cemented to the bottom to prevent skidding and marring table tops. Handles at both ends make it easy to carry while a push button catch on the drawer prevents it sliding open if the box is tilted while moving it about. The size of the drawer is such that the vertical column and arm will fit inside easily.

A cloth cover is arranged to fit into clips at the back when the lathe is in use. It is made from upholstery material.

This box base has greatly improved the setup time as all attachments are always with the lathe and ready at all times. The weight of the attachments also adds to the stability. A final point in favor of this base is that the increased height brings the work nearer eye level.

I didn't like changing those tight belts, so I made a speed control for the motor. This was attached to the idler pulley mount. Last of all, the line switch which came with the lathe seemed unhandy, so the motor switch was built into the speed control.

SOURCE FOR SPRINGS

Scrounging is an important part of participation in metal working hobby activity. As you will note in these articles it is often suggested that you "search through your spring collection" for example.

A good source for springs can be found in present-day typewriter ribbon and computer ribbon cassettes or cartridges. The plastic cases can be pried apart easily with a screwdriver and you will often find two or three small springs used to keep tension on the ribbon.

Another source for springs is found in worn-out ball point pens. These often have a long, small-diameter spring to actuate the extension and retraction of the point.

If you don't have direct access to discarded ribbon cassettes and cartridges, check with the secretary at the office, family members or friends who hold jobs where it would be no great problem for them to watch for these sources. Thousands of fine small springs are thrown away every day! They are mighty handy in your shop.

Cutting a Tapered Keyway

The flywheels for a small hit-and-miss engine called for tapered keyways. This is how they were made.

A small bar, similar to a boring bar, was made. The cutting bit was made the width of the keyway and the bar mounted in the boring tool holder, carefully centered. The tiny cutting bit was set to cut when pulled (not pushed) through the 5/16" shaft bore. As shown, a pin was built into the cutting bar at 90° from the cutting bit to serve as line-up for setting the bit on the horizontal center. The pin was sighted parallel to a square resting on the lathe bed.

The flywheel was centered in the 4-jaw chuck and rotated so two jaws were horizontal, then the spindle locked in backgear. The top and front jaws were backed up only enough to be able to move the gear. Note the

counterweight that was built into the casting and centered on the front jaw. The keyways in the engine crankshaft were centered opposite the crank throw so, when assembled with the flywheel, the counterweights were in the right relationship to the crank.

A .043" diameter pin was placed under the flywheel at the front jaw and the two jaws carefully tightened. This .043" pin positions the flywheel at an angle of 1/8" taper per foot.

The lathe cross-slide was backed up until the cutting bit just touched the 5/16" bore at the outer face and the collar set at zero. The bar was run through the hub, backed up .004" to .005" and the bar drawn out of the bore. By taking the light cuts, using the lathe carriage like the ram on a shaper, the passes were made until the tool was backed up a total of

.047". An inside measurement across the bore plus keyway depth should be 5/16" plus 3/64" equaling 23/64" at the outside edge (.359" measured with a Vernier caliper.)

The gib-head key (you just learned another machine term) was made parallel at 3/32" and tapered carefully with a file, bit by bit, until it fit the keyway in the assembled flywheel and crankshaft. Only about .008" had to be removed at the narrow end.

An expert with a tiny file may be able to file the .008" taper after making the keyway to the shallow depth. This method described above seemed more accurate. You may have use for this bar again some day. Setting the compound at 35 minutes, 47 seconds, might be difficult and you don't have much leverage for pulling the bar through the cut.

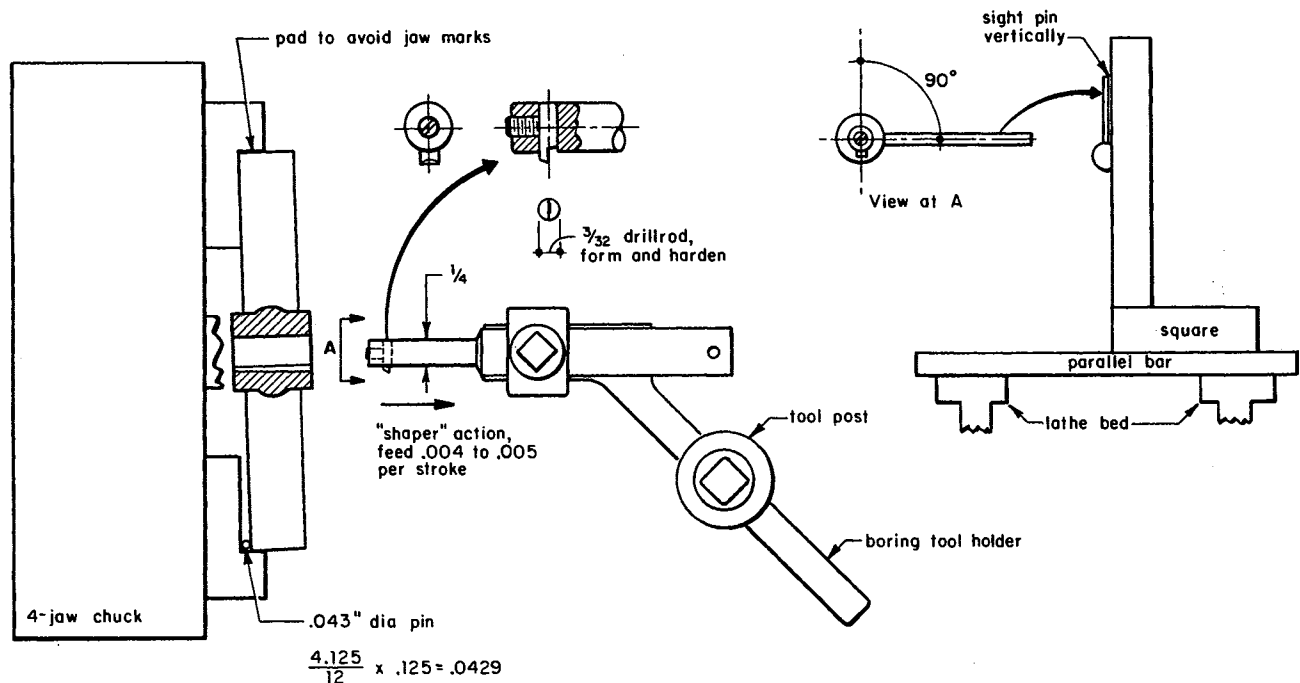

ref. 1/8 taper per foot = 0° 35' 47" included angle
 ref. taper in 15/16 hub length is .0085 approximate

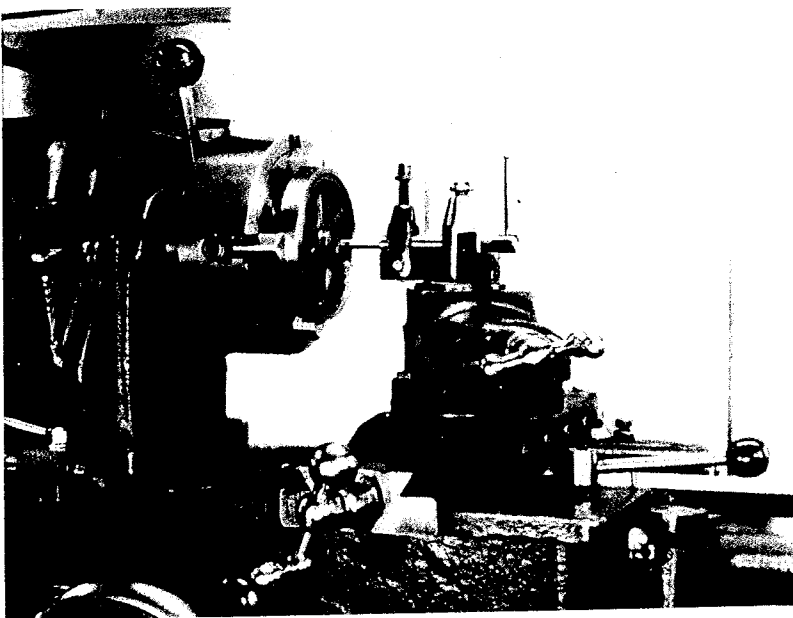

The flywheel and tool mounted on the lathe.

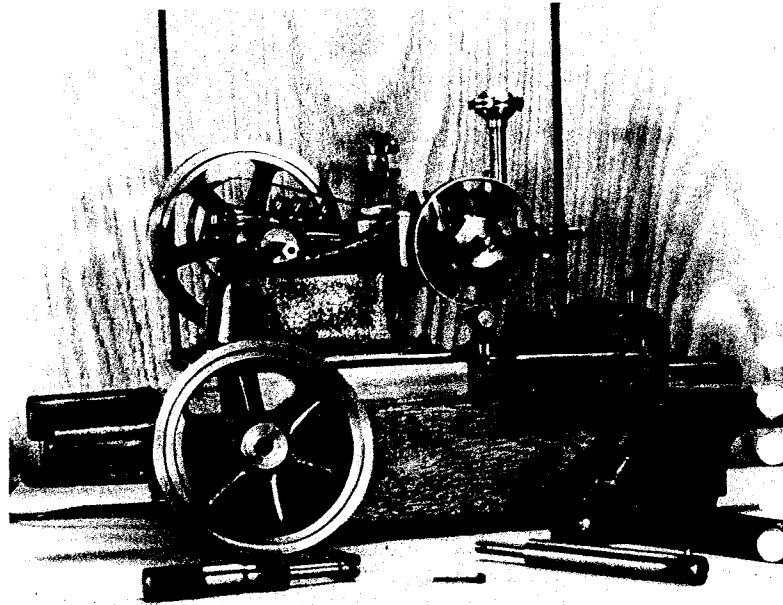

The hit-and-miss engine, flywheel and tool.

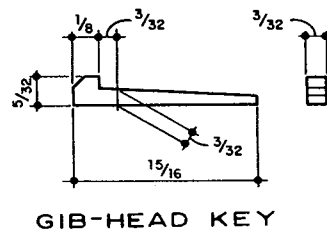
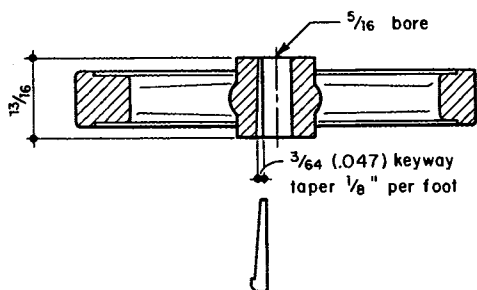
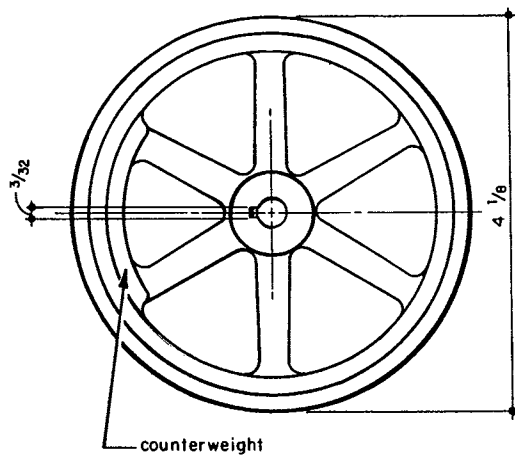

Modelmaker's Depth Gauge

On most Depth Gauges, you must hold the body of the gauge and also hold the Plunger down while tightening the Thumb Screw. This one is spring-loaded and you are more sure of the measurement. The Thumb Screw is up away from the work and easier to tighten. The 1/16" diameter pin reaches into holes as small as the tap-drill hole for a 2-56 thread.

The material is optional. On the Gauge shown, the material is steel except for a brass Tube and Ball.

The construction is mostly straight machine shop turning and threading. The face **A** of the **LOWER CAP** should be square with the axis of the Pin. The main **TUBE** is soldered into the Lower Cap and threaded 1/4-40 into the **UPPER CAP**. The 40 series taps and dies are great to have on hand for threading thin wall tubing and threading close to a shoulder as on a packnut. If you don't have 1/4-40, you might try a short 2-56 or smaller screw as shown. The Tube should be a close fit in the Upper Cap.

Before final assembly, give all the inside parts a coat of light grease. If you choose to knurl, a squeeze type of knurling tool is almost a must. The 1/4" Ball is optional. This can be a fancy little turning if you wish.

The **SPRING** used here has the proportions shown. If anything, it is a bit stiff. The wire diameter could be reduced about one gauge size. Try one of the springs in your collection. You may have just what it takes.

You can use the depth-measuring slide on your vernier caliper to measure the projection on this gauge and have the dimension within a few thousandths of an inch.

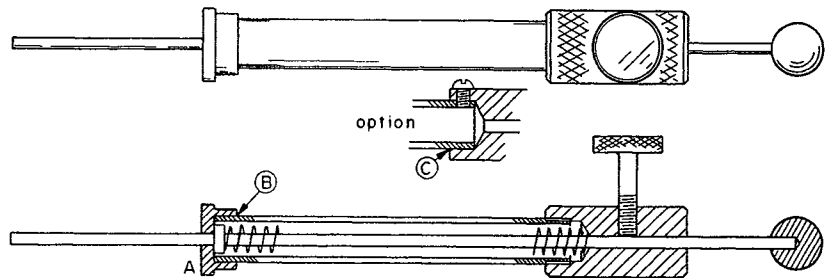

DEPTH GAUGE

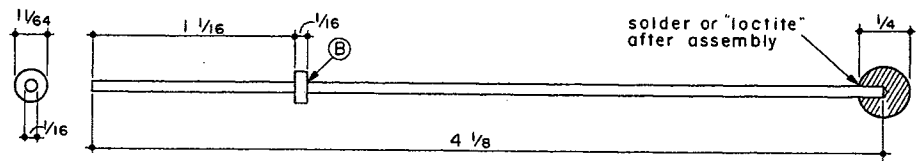

PLUNGER
Steel

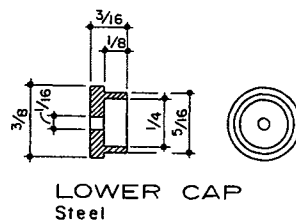

LOWER CAP
Steel

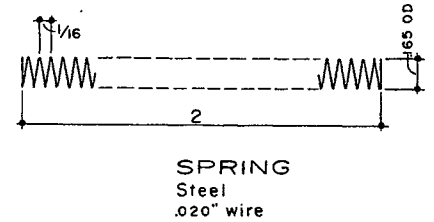

SPRING
Steel
.020" wire

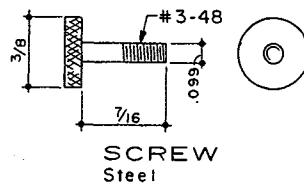

SCREW
Steel

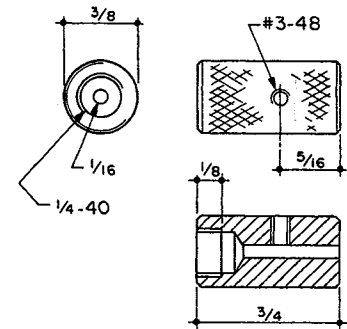

UPPER CAP
Steel

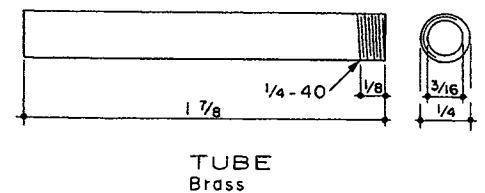

TUBE
Brass



Modelmaker's Thickness Gauge

This is a gauge or caliper for measuring in places a standard caliper or mike cannot reach. It is a companion to the Depth Gauge on the opposite page. This tool can be spotted on the part you wish to measure and it will cling so it is quite self-aligning.

The material is free-machining steel except for the brass Tube on the one shown here. The machining is mostly standard machine shop practice and duplicates the procedures for the Depth Gauge. Any exceptions will be mentioned below.

The **LOWER CAP** and **SCREW** are the same as shown on the Modelmaker's Depth Gauge drawings.

The inside face **A** of the Rod Flange and outside end **B** of the Lower Cap should be flat and square with the axis of the gauge for best results.

Assembly of this gauge is a bit of a problem. Make the 1/16" **ROD AND FLANGES** as shown. Solder the end flange and "true-up" the inside face if necessary. When you are satisfied with all the parts, assemble the Tube, Rod and Spring with a coat of grease. Wipe the Rod clean at 1-25/32" area. Slide the 5/32" Flange in place so it enters the Tube about 1/32" (this is to prevent catching on the end of the Tube). Hold the Rod in a vise or clamp in this position and add a drop of solder. A 1/4" length of about 1/8"

aluminum wire between the 5/32" Flange and the vise jaw will give you a more open soldering condition with less heat conducted away by the vise jaws. The Spring pressure will hold it in place while soldering.

Measuring this gauge with the inside jaws of your vernier caliper will give you readings accurate to within a few thousandths.

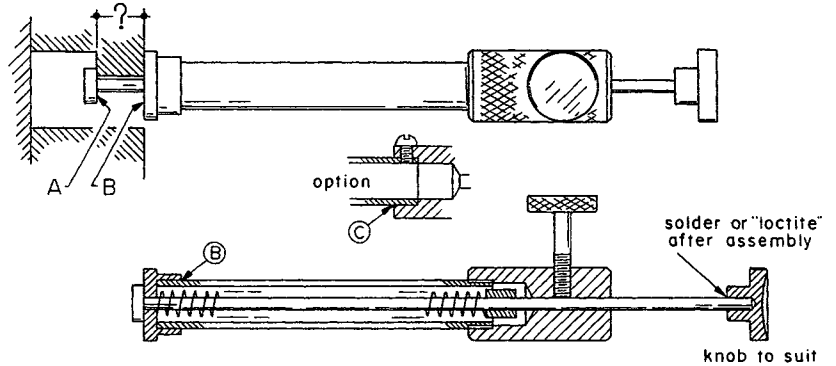

THICKNESS GAUGE

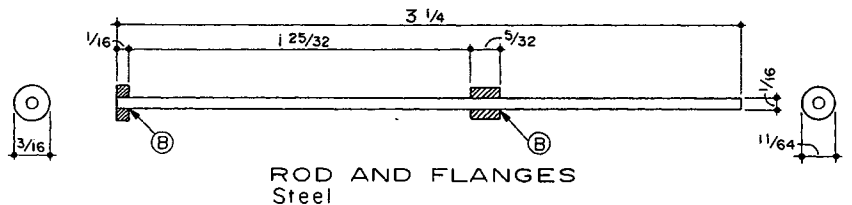

ROD AND FLANGES
Steel

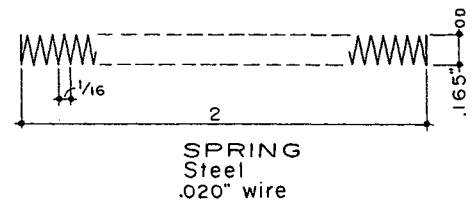

SPRING
Steel
.020" wire

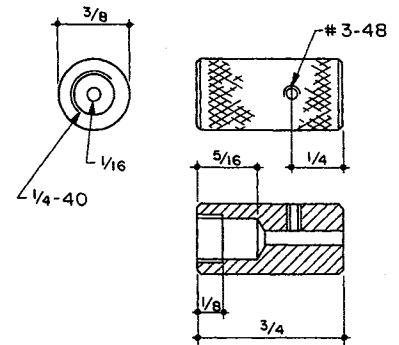

UPPER CAP
Steel

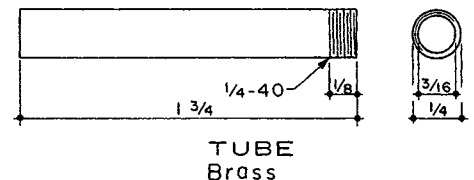

TUBE
Brass

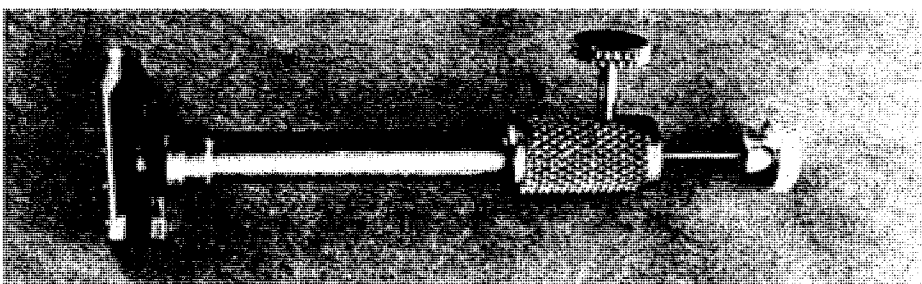
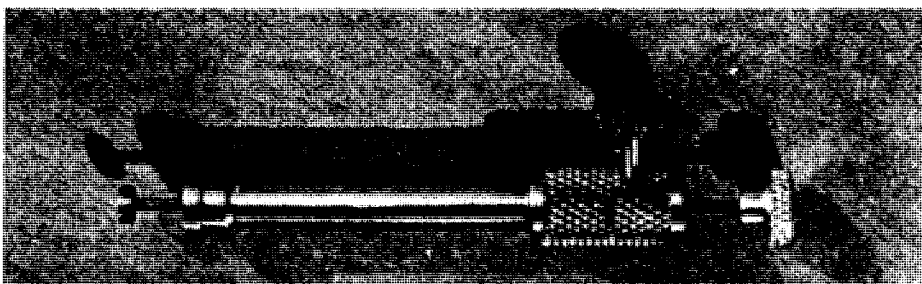

The Modelmaker's Thickness Gauge is shown in the upper photo and in use, measuring the thickness of a brake clevis, in the lower photo.

Sheet Metal Punch

This is a general description, with a few dimensions, of a punch made several years ago. It was made almost entirely of salvage material. You may feel that you don't need as great a throat capacity and you can build it to suit your needs. The photo shows a brakelining tool conversion which started this project. It did a pretty good job, but had a few shortcomings.

The greatest feature on this Punch is at **A**. Most simple punches do not provide a point where pressure can be applied with the fingers while spotting and striking with a hammer. This feature of being able to hold the sheet firmly makes it possible to punch out washers, especially thin ones, for tiny models.

Say you want a .004" spacer 1/4" I.D. x 3/8" O.D. First, punch a 1/4" hole in the shim stock. Remove the 1/4" die and insert the 3/8" die. Run the 1/4" punch down through the 1/4" hole just punched. Hold the sheet in place and remove the 1/4" punch. Insert the 3/8" punch with your other hand. Strike a sharp blow and you have an accurate spacer if the punch and die are sharp and clearances small.

About those clearances just mentioned: on the examples shown, only about .001" was allowed on the diameter. According to the handbooks, the clearance goes up as the metal to be punched gets thicker. This outfit has been used many times on material from shim stock to common galvanized steel and from a plastic bill-fold calendar to 1/32" rubber and fibre gasket material. The more clearance, the more ragged the hole.

Punches **B** and **C** show a mild steel body with hardened drill rod pressed into the end. Punch **D** is all drill rod with a mild steel cap. **E** shows a typical die that should be made of tool steel. The dies on this outfit are case-hardened steel since no tool steel was on hand at the time. Punches **C**, **D** and **G** show the cutting edge curved to start the shearing action. Detail **K** shows how this was done on a small grinder. **G** shows a tapered shank which was not included in the punches

made originally but will be considered next time to make it easier to pull the punch out of the sheet stock. About 1° taper should help. **F** shows another type of cutting edge that is turned to provide a center point which gives aim at a prick punch mark or centerline. It doesn't lend itself to resharping.

Another point in favor of this tool is the guide which takes away one lineup problem. By holding the stock against the guide, you can make a series of holes located accurately from one edge. You only have to spot in one direction.

The extra removable bar, **H**, makes it possible to actually scallop the edge of a sheet.

Note the 3/16" dimension at **J** which is equal to the 3/16" dimension at the top of die **E**. Any size punches you wish can be made up to 3/8" diameter.

A future possibility for this tool is a rest block which would straddle the base and a slide block on the upper arm, held with a thumb screw. The slide block would have a spring-loaded, sharp-pointed pin to enter a prick punch mark in the center of a circular blank so a series of holes

could be made in a circular pattern.

Another future addition could be a lever, perhaps like a crowbar, to help pull the punches out of the sheet metal. On some material, it is hard to remove the punch. Punch presses have strippers for this purpose.

The kind of material, thickness, clearance, sharpness and punch alignment all affect the quality of the resulting hole. Out in industry, each punch set is designed to meet the material and hole quality called for in the part. Here, we have a single outfit for a variety of materials. This has been a good, all-around tool for light duty.

By turning some special punches, it would be possible to set snap fasteners, eyelets and rivets. The kits of eyelets and snaps have a tool that could be inserted in a special punch and die. A flairing tool for hollow rivets and a hemispherical header for solid rivets can also be added.

This tool came in very handy when making the sheetmetal lagging for small engines and boilers. Why not start one now for your shop? It will be a most useful addition to your shop equipment.

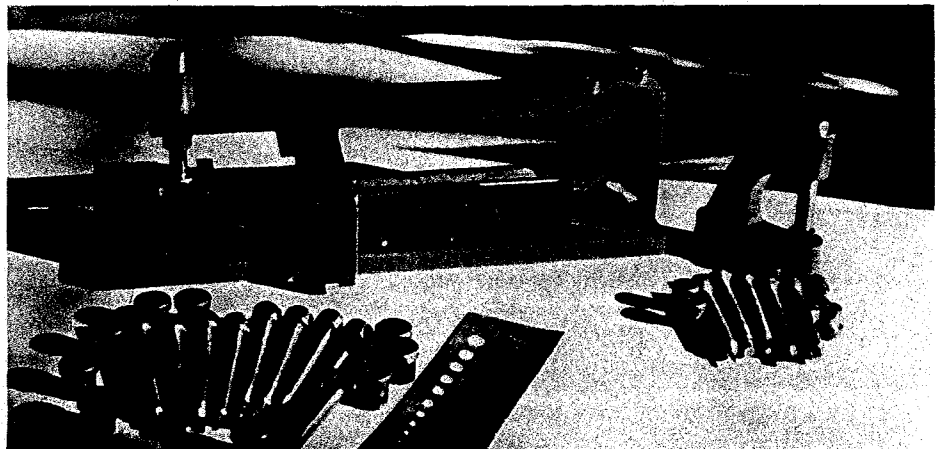

Safety First — and Always

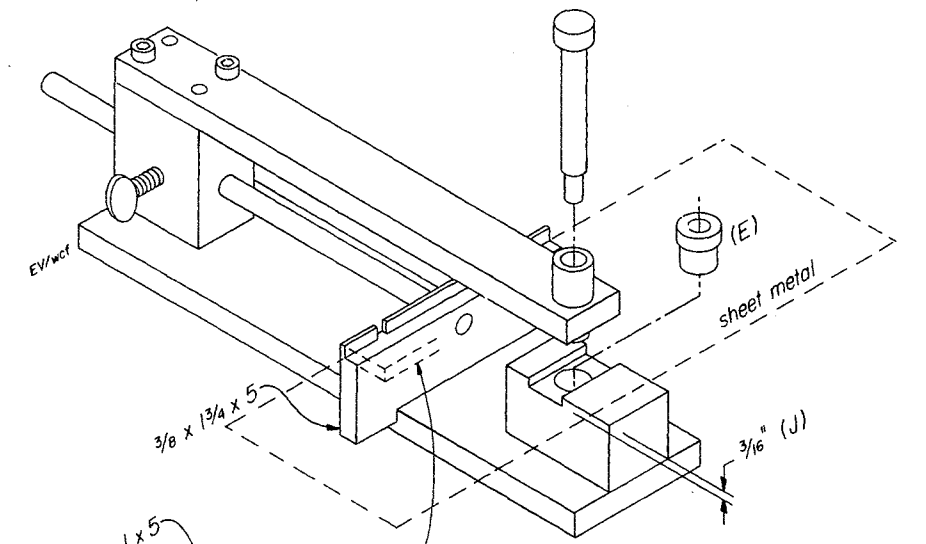

SHEET METAL PUNCH

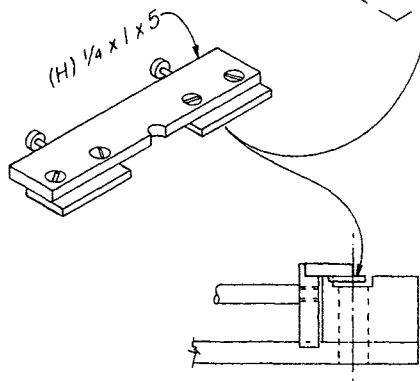

(K) Punch D clamped to V-block and shimmed to center on grind wheel

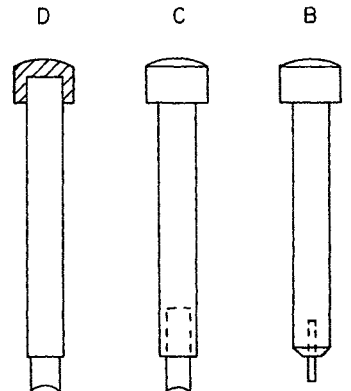
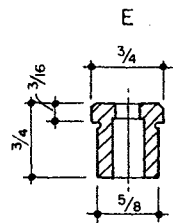
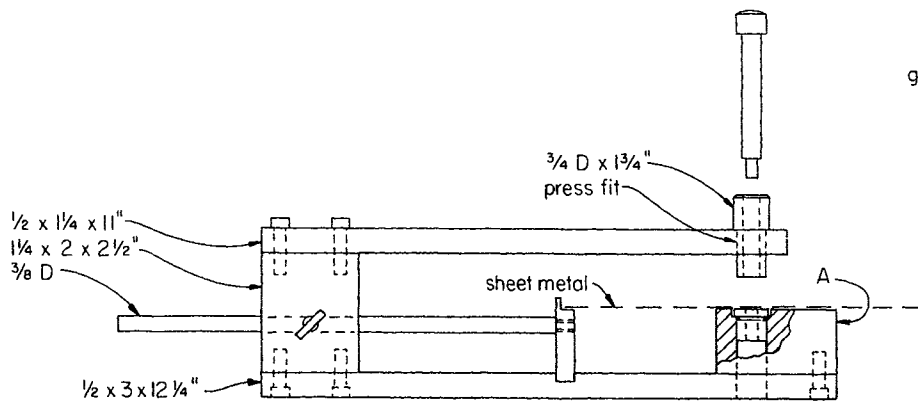
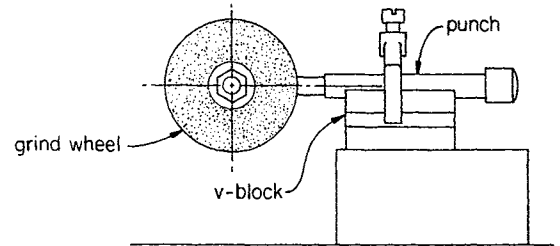

A Beam Compass



A Beam Compass is a project in some shop classes. This compass is different and has a feature not found in other designs. This one has a means to hold many different types of scribes and cutters.

The construction is common machine shop practice. The material is mostly aluminum with brass screws. The micrometer screw is steel.

The flats on the **BEAMS** can be filed by hand or milled in a cross slide milling attachment in the lathe.

The **VEE BLOCK** starts as a 3/8" x 3/4" x 1-3/8" block. All lines and

centers are scribed and the three holes drilled. The V cut is either milled or done in the shaper. The slot for the Loop is centered on the 9/64" hole and finally the 1/4" x 13/16" corner cut away.

The needle shown is found among common drafting compass material.

Make several **LOOPS** to adapt the various scribes you will be using. The 21/64" hole is about right for general purposes.

On the **CENTER SPINDLE**, lay out and drill the 1/4" and 5-40 holes first. The drill will catch on the shoulder if you thread 3/8-24 first. Turn, knurl and thread 3/8-24. A squeeze-type knurling tool is required to get a deep knurl. Chuck on the 7/16" diameter and turn the needle end.

The **ANCHOR** is first drilled 1/4" and 9/64", then the end turned and threaded 3/8-24. Grip in a V groove in the milling vise and mill the 1/8" slot. You don't have much of a grip on this piece, so take it easy. File or mill the taper.

This is another tool that will give you a few evenings of pleasure in your workshop and many years of service.

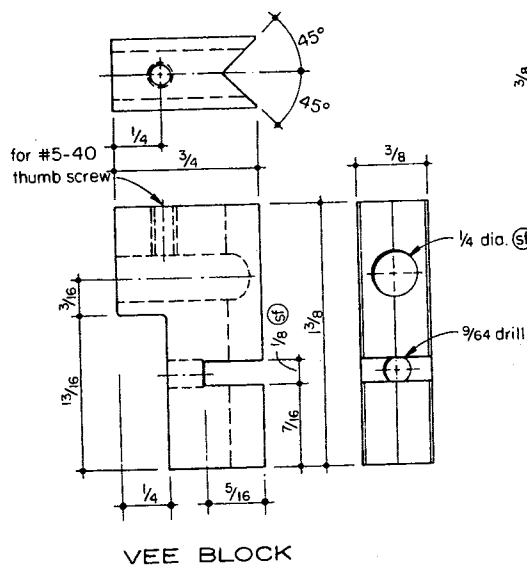

VEE BLOCK

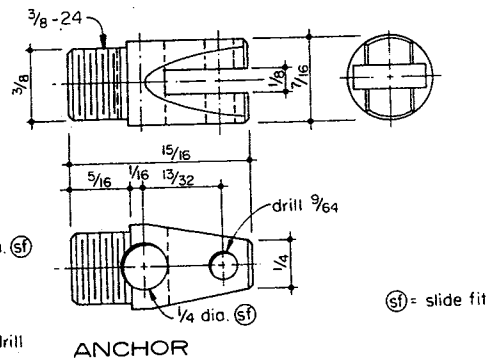

ANCHOR

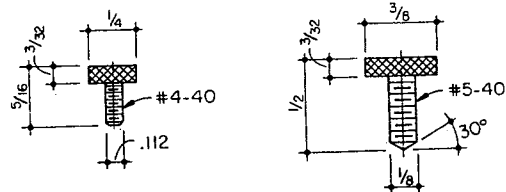

1 Required for Center Spindle
THUMB SCREWS

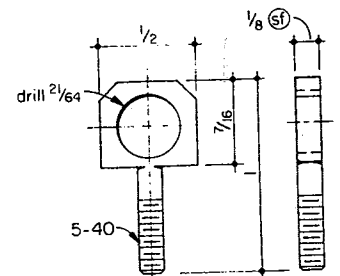

LOOP

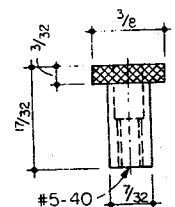

LOOP NUT

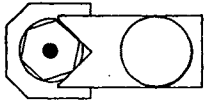

also can be adapted to accept
 ball point and felt tip pens
 steel scribe
 Mars, Rapidograph and Wrico inking pens
 Exacto knife
 draftsmen's ruling pens
 soapstone, chalk and crayon

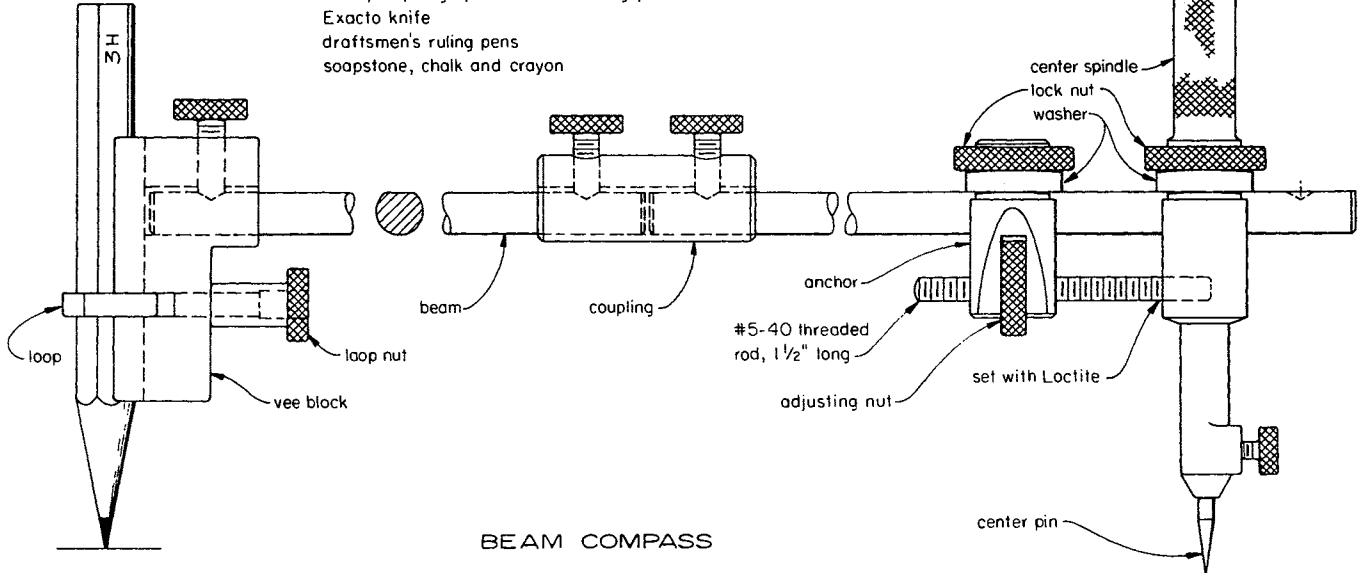

BEAM COMPASS

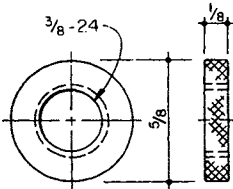

LOCK NUT
 2 Required

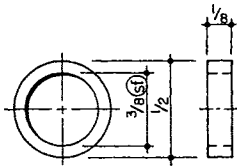

WASHER
 2 Required

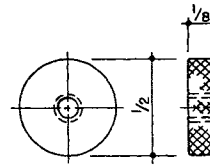

ADJUSTING NUT
 1 Required



CENTER PIN
 1 Required

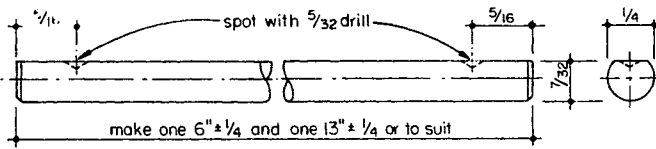

BEAM
 2 Required - lengths as indicated

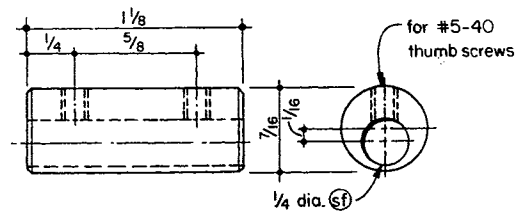

COUPLING
 1 Required

(SF) = slide fit

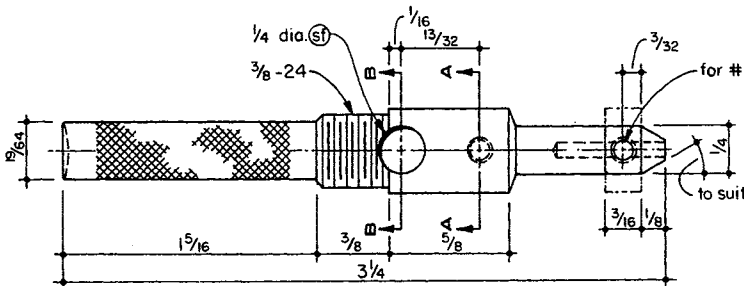

CENTER SPINDLE
 1 Required

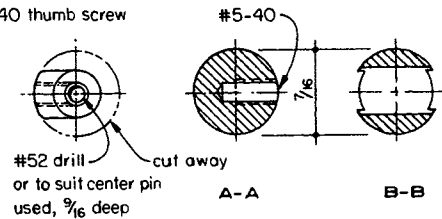

Simple Turning and Machining Hints

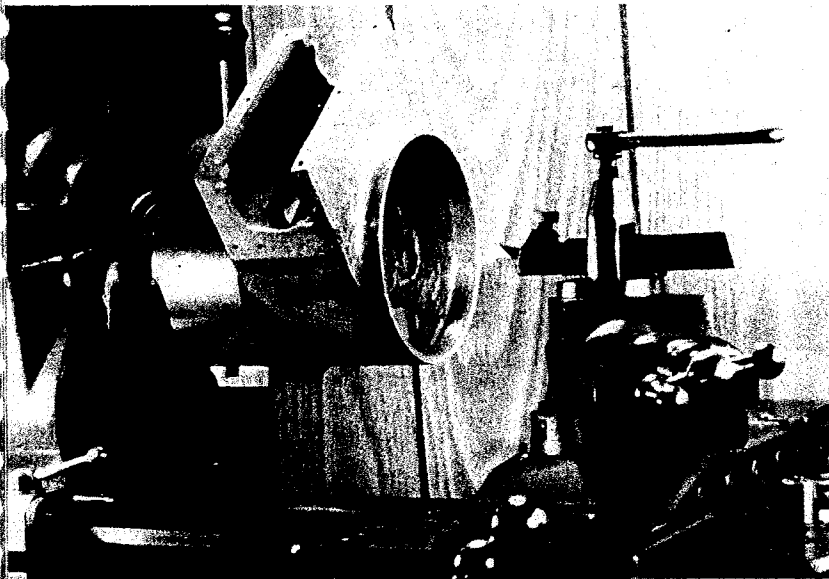

A one-piece aluminum locomotive smoke box required machining on a flange that meets the boiler. After cleaning up the casting with a file and checking for squareness, etc., it was ready for turning. The 8-1/2" face plate on my 12" lathe didn't leave much room for clamps.

A 6" 4-jaw chuck was finally used. Two jaws gripped the outside and two jaws the inside of an opening opposite the flange to be turned as shown on the sketch below and the photo at the left. It held good and, with light cuts, the flange was turned to size. You have to study and try ideas for such jobs. You will not find anything in a book telling you how to do such an operation. This was a simple solution that didn't require any special clamps or fixture.

The next operation required the bottom edges to be machined square with the axis of the box and a definite distance from the boiler centerline.

The 8-1/2" face plate and an angle plate were used as shown in the lower photograph. A sheet of brown kraft paper between the work piece and the angle plate can reduce the threat of slippage.

The process required a jump cut; but, by taking light cuts and a bit of time, the bottom was machined to print. Note how much overhang there is and the need for extra care.

Good use was made of the carriage stop. It was backed up .015" to .020" for each cut and no great shocks went through the piece while turning. Also, a heavy block of steel was clamped to the face plate to help counterbalance the offset weight.

This is just another tip to keep in mind, along with a word of caution for a clumsy, whirling, knuckle-buster.

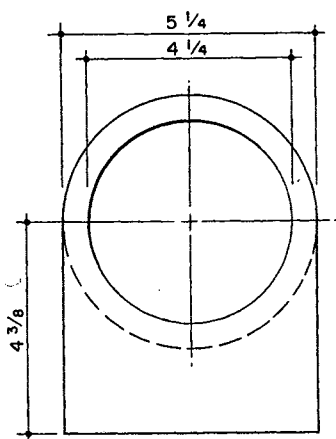
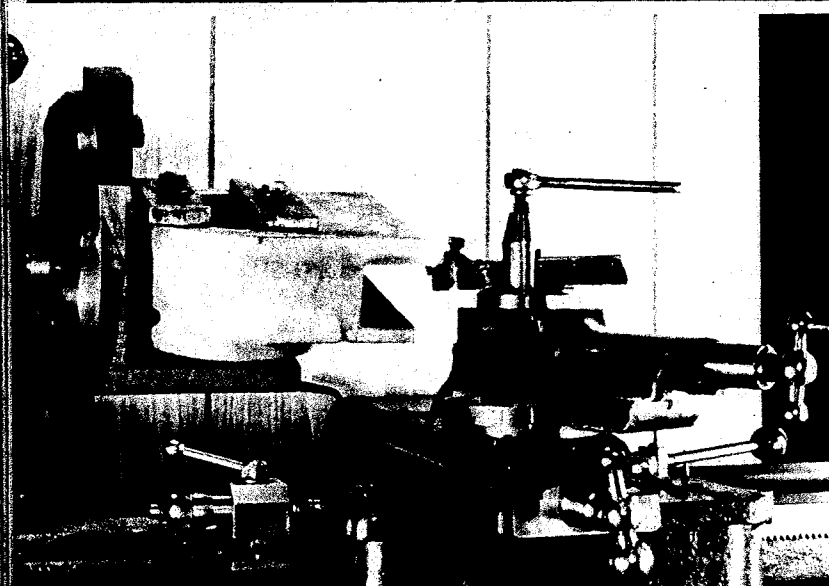

SMOKE BOX

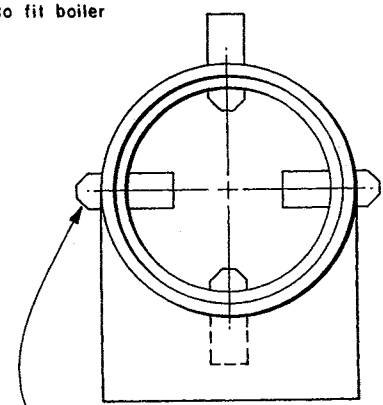
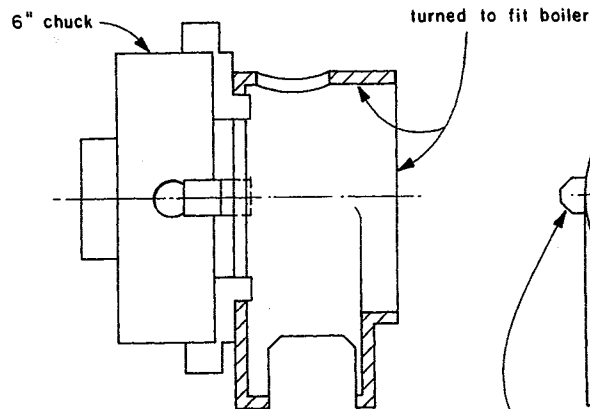

jaws (reversed) grip outside

EV/jiw

Adapting

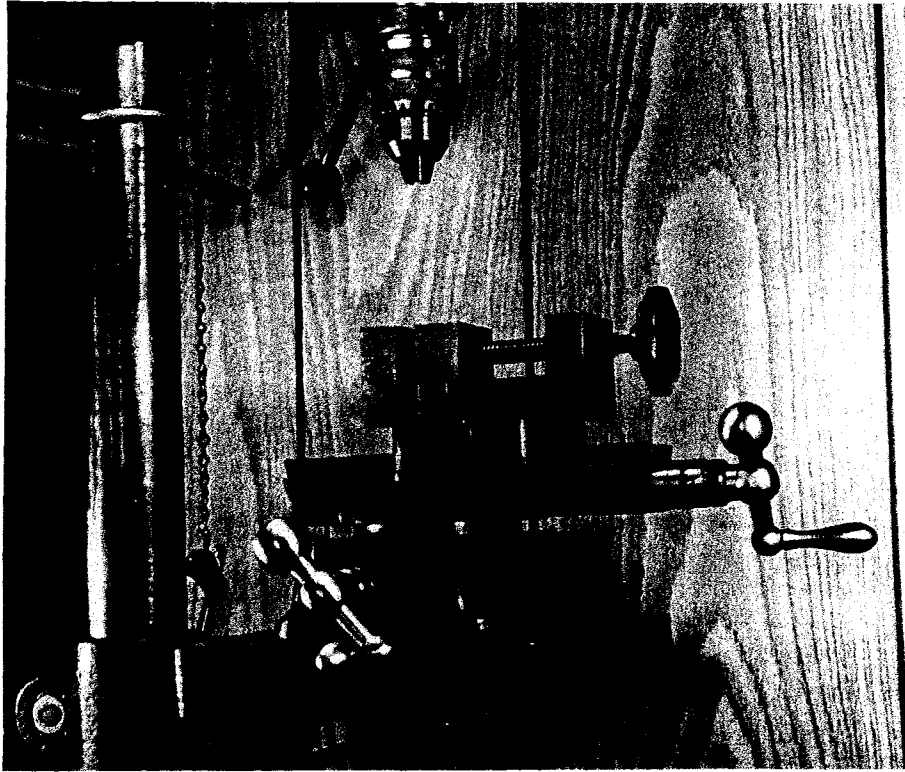

If you have the #965 slide rest for the Delta #1460 12" wood-turning lathe, you have the base for a cross-slide vise for your drill press.

Remove the bottom lathe adaptor plate and mount the slide directly on the drill press table. Fit a bar in the top slide T-slot and attach a small drill press vise to it. You do not drill or otherwise alter the slide so it is always available to return to the lathe.

Your vise will determine the type of clamping you will use. Two 1/4" set-screws hold the bar in the slide and two special clamps engage slots in the side of the vise. Keep the top of the bar below the top of the slide so the vise will bear on the slide when clamped.

This is still another way to get additional use out of your shop equipment that might otherwise be setting idle.

O&E/B

Hardening

As an amateur tool maker, I spoiled more hours of work than I care to remember, trying to harden drill rod products by heating them to "cherry red" as specified in various articles. You don't have to misjudge the color by very much to "burn" steel by overheating it.

When steel reaches its critical temperature for hardening, it loses its magnetic properties. This fact of life provides us with a nearly foolproof method of indicating that it is hot enough. As you heat the part, just keep touching it with a magnet. When the magnet ceases to attract it, the part is the right temperature for quenching.

Frequently, I find it convenient to hold parts similar to the centering pin (i.e., special milling cutters) in a holding device in the chuck of my drill press, and then lower it into the quench when it reaches critical temperature.

I've been batting a thousand in my hardening operations since I adopted these methods.

Luke Lukins

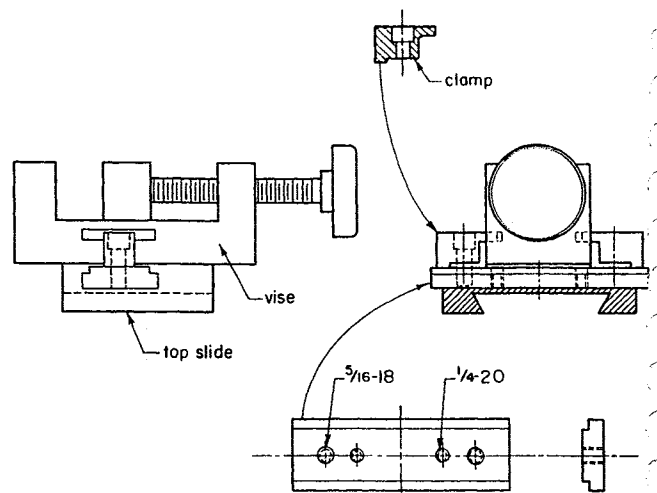

Ball Turning Tool

This is a handy item for the metal-working hobbyist; it is not a production tool. A 1" diameter ball can be made with surprising accuracy and finish. Unlike some ball turning attachments featured in past shop

articles, this one does not require removal of the compound- or cross-slide. It goes into the tool post slot in the tool rest and requires about the same setup time as a boring or threading tool.

Some proportions have to be adapted to your lathe since this design is for lathes that have a 1" diameter tool post. The closer you make the fit of the rotating block, the better will be the accuracy and finish of the

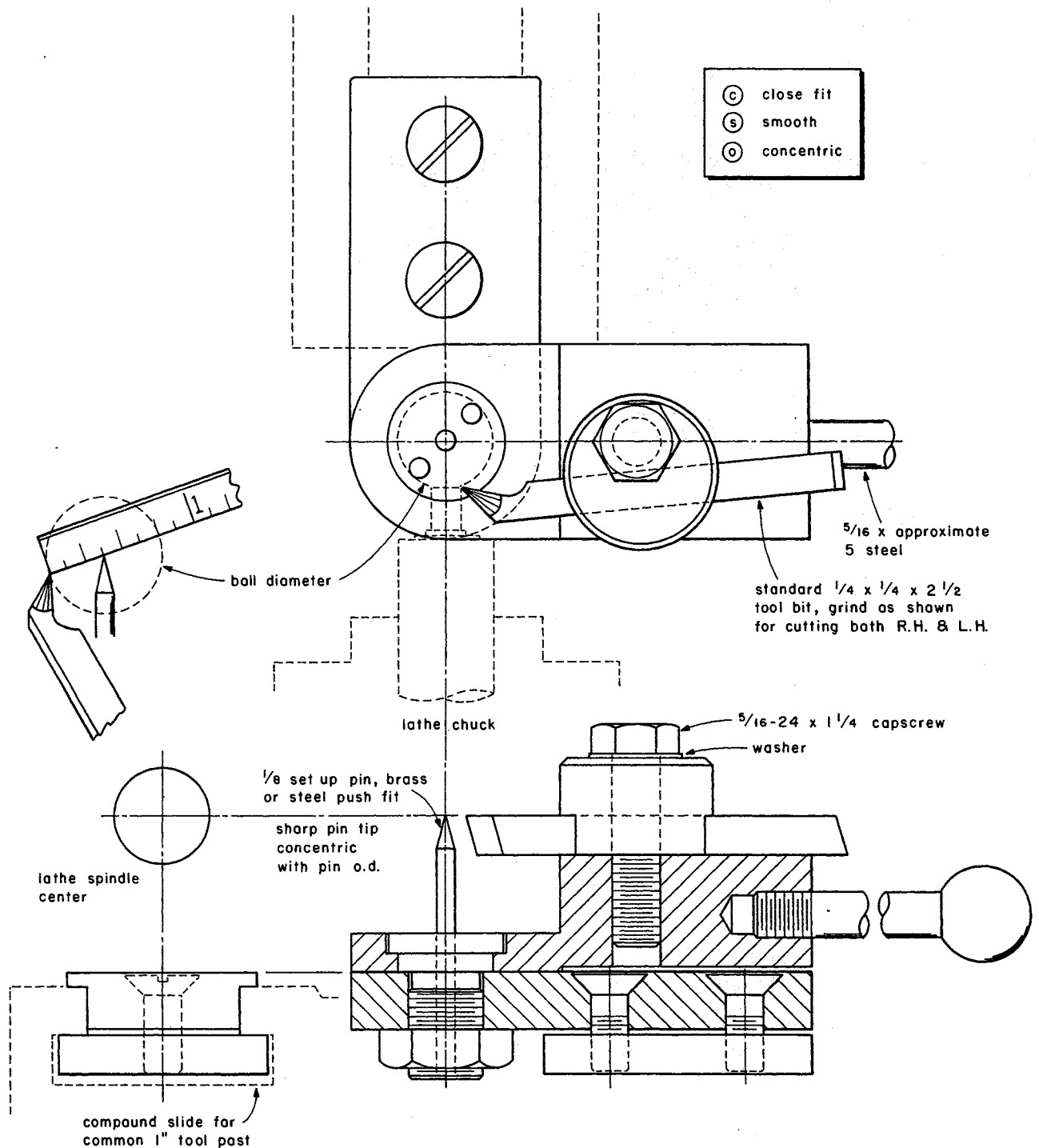

ball. There should be no looseness in the **TOOL BLOCK**, and concentricity is quite important between the shoulder screw bearing diameter and the 1/8" hole for the setup pin.

To make a **BALL** for the end of the Lever for this tool, a "squarish" over-size ball is roughed out by eye with standard lathe tools. This is faster since the Ball Tool is not a roughing

tool. The "neck" left supporting the ball can be quite thin because the final cuts will be very light. Bore about 2/3rds through for a drive fit on the Lever Shaft. Chuck the Lever with the rough ball about 1" from the jaws.

Mount the tool on the tool rest, overhanging to the left. Insert the setup pin and run the cross-slide in

until the sharp tip just barely touches the sharp point of the tailstock center. A magnifying glass is handy here. Set the cross-slide collar to zero. Now set the tool bit half of the desired ball diameter away from the sharp tip of the setup pin, well to the left so the tool body will not strike the chuck before completing the left side of the ball. Remove the setup pin

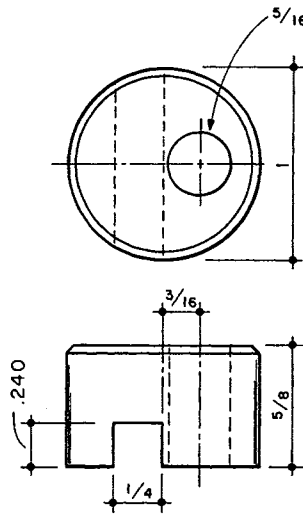

TOOL POST
Steel

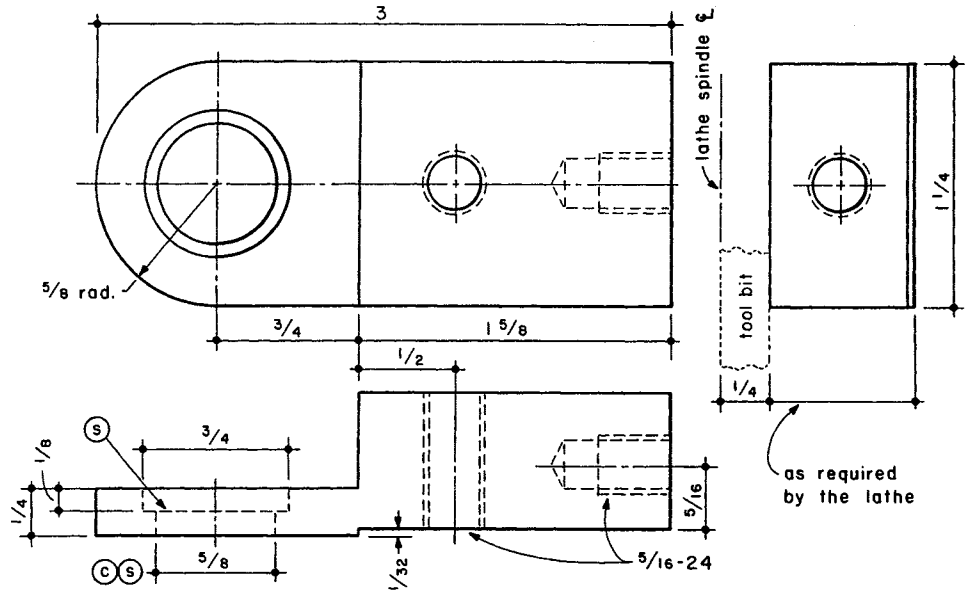

TOOL BLOCK
Steel

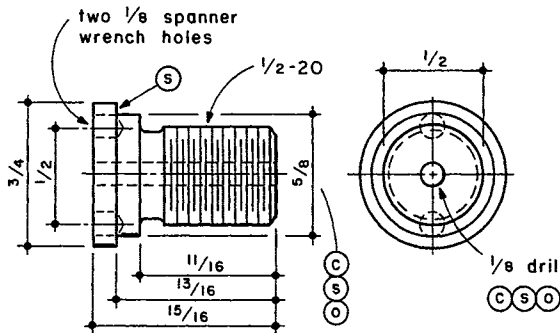

PIVOT SCREW
Steel

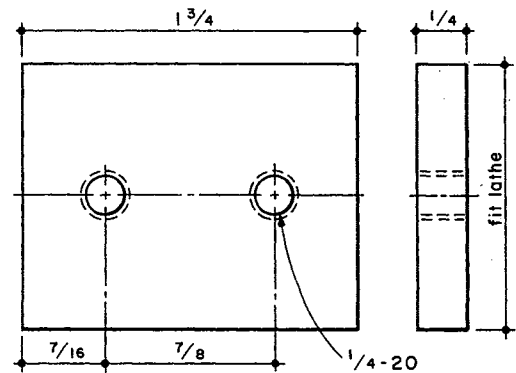

CLAMP
Steel

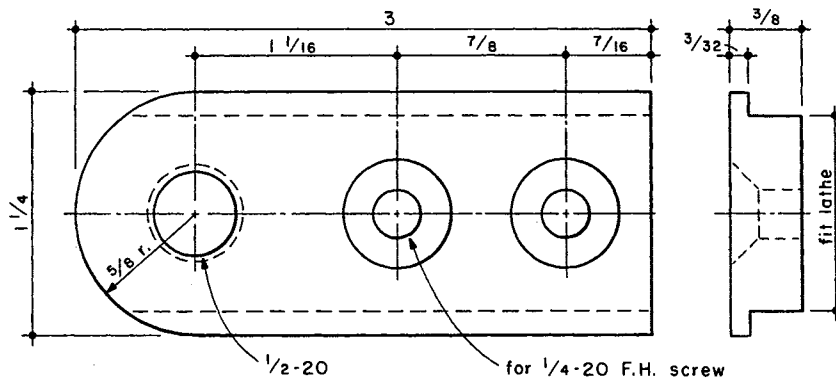

BASE
Steel

and, with the tool bit to the right, run the carriage until the tool pivot is under the rough ball. Use a 5/16" bolt as a temporary lever. With the cross-slide still at zero, stop the carriage when the cutting tip of the tool bit just touches the rough ball at the spindle centerline. Back the cross-slide away and move the carriage left .010" to .015" and lock it. This leaves "finish" on the right hand side of the ball. Now start turning the ball with

very light cuts. Advance the cross-slide slowly, at the same time rotating the Tool Block, looking for the first sign of cutting. Make 180° turns of the Lever after each advance of the cross-slide.

As the ball takes shape, you can compensate slightly right or left with the carriage to "clean up." When the cross-slide reaches zero, you should have a round ball close to the desired diameter.

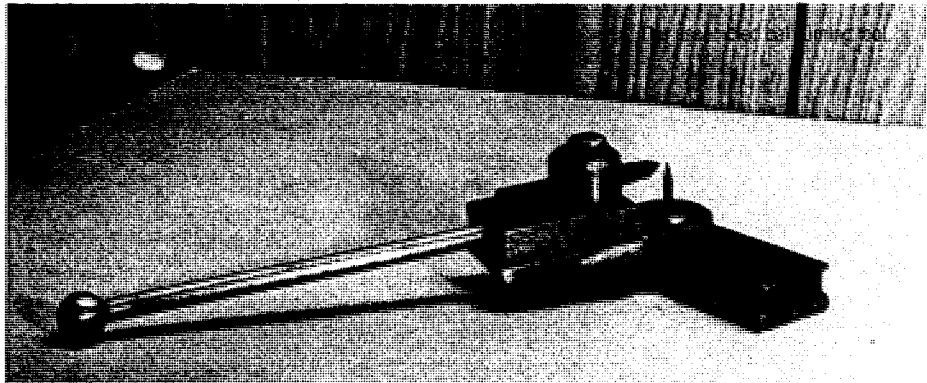

The tool mounted on the lathe and a ball which it turned.

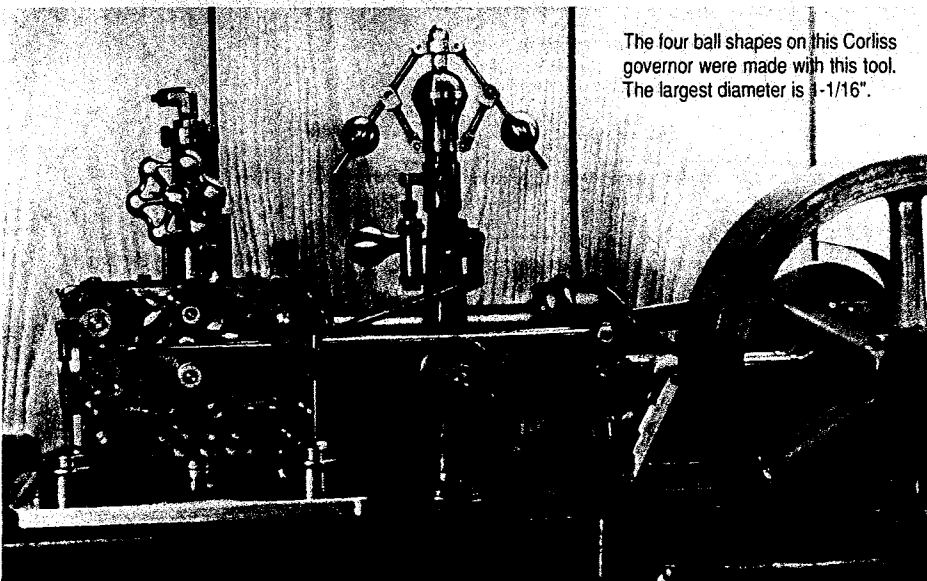
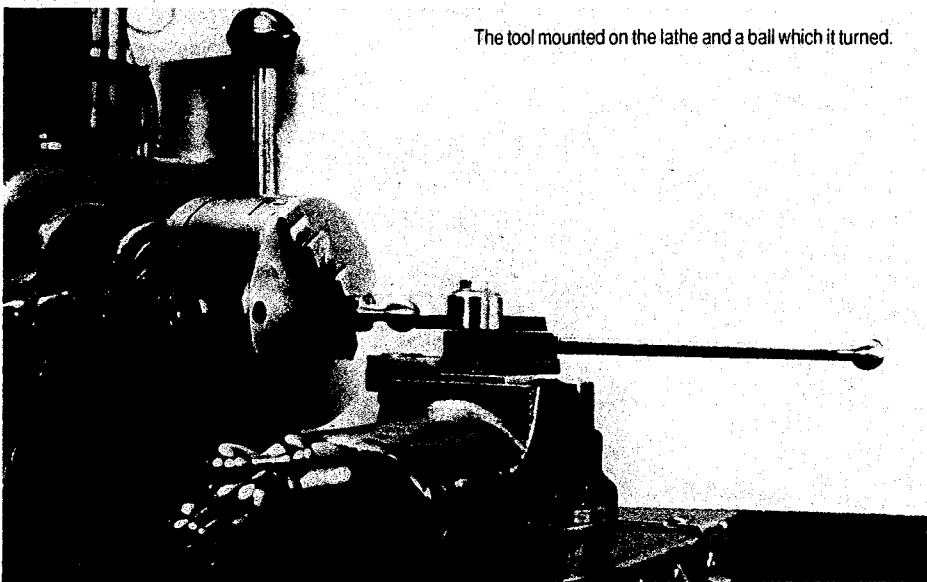

The four ball shapes on this Corliss governor were made with this tool. The largest diameter is 3-1/16".

O&E/B

Close Tolerance Holes

There are times when a hole is needed with a minimum amount of clearance between it and the mating part. A reasonably close tolerance can be held using a couple of drills and an end mill.

A drill press can provide accurately drilled holes, but if accuracy of position is also needed, a mill or lathe is needed.

Drills have a tendency to cut oversize. This is more noticeable with a drill bit that has been reground. The main cause is due to different lengths of the cutting surfaces, regardless of how small the difference.

To get around this problem only requires a couple of simple steps. First, drill a pilot hole to within 1/16" of finish size. The second step is to use an end mill whose diameter is within .010/.020" of finish size. The end mill will cut like a boring tool and align the hole true to the spindle. This should be done at a slow feed to reduce any tendency to deflect.

Caution — when doing these steps, the part must be held firmly on the machine because the end mill will have a tendency to throw the part when it first enters.

The last step is to drill to final size with the correct drill bit.

Doing these three steps will eliminate the effect of the differences in the cutting lengths of the drill bit and save the cost of buying a reamer or the time and effort needed to bore the hole to the finish size.

Larry M. Boyce

Carriage Stop

When converting an old 9" lathe to a milling machine, I needed a Carriage Stop. When a cut is completed and measurement shows say .005" more should come off, this Stop can be advanced or backed up .005" and a light pass made.

The lathe has flat ways so the Stop is simple. The **BODY** of the Stop is tap-drilled for the 1/4-20 Stop Screw and then used as a guide in drilling into the carriage for a Stop Button, using a small electric hand drill. It can then be tapped 1/4-20 for the Stop Screw. Try for a close fit on this thread to reduce backlash when making a setting. This is an opportunity to cut a thread in the lathe, using the Block as a gauge. When the Stop Screw starts to enter the Block, take very light passes until it will enter the Block with a close fit.

Twenty threads per inch is a good size for measuring in thousandths; one turn of the screw advances .050". The collar being small, only 25 divisions were made. It is easy to estimate 1/2 a space for .001". One space is .002".

The Bar for reading the Collar is a short piece of a broken 1/4" wide pocket scale. It is a light drive fit in the hole. The centerline of the hole is 1/32" above the Collar and 1/8" back of the Collar centerline. Start the Scale in the hole and bring "0" around to the Scale edge and the Collar face approximately 1/8" from the Block. Drive the Scale in until a 1/8" mark is even with the face of the Collar while "0" is at the edge. It is good if the Scale is

bearing slightly against the Collar to reduce creeping of the Screw.

Note the 3/16" Guide Pins also serve to back up the rear of the Clamp. This is a cut-and-try operation. When you are satisfied, set the Pins in the Clamp with Loctite. The ends of the Pins can be cone-shaped to match the drill point in the holes.

A thin washer may be needed under the Clamp Lever to bring it up tight at the right of center.

It is rare that your lathe has the proportions of this old lathe, so you will have to adapt to your lathe. This is a simple but quite accurate addition to your lathe.

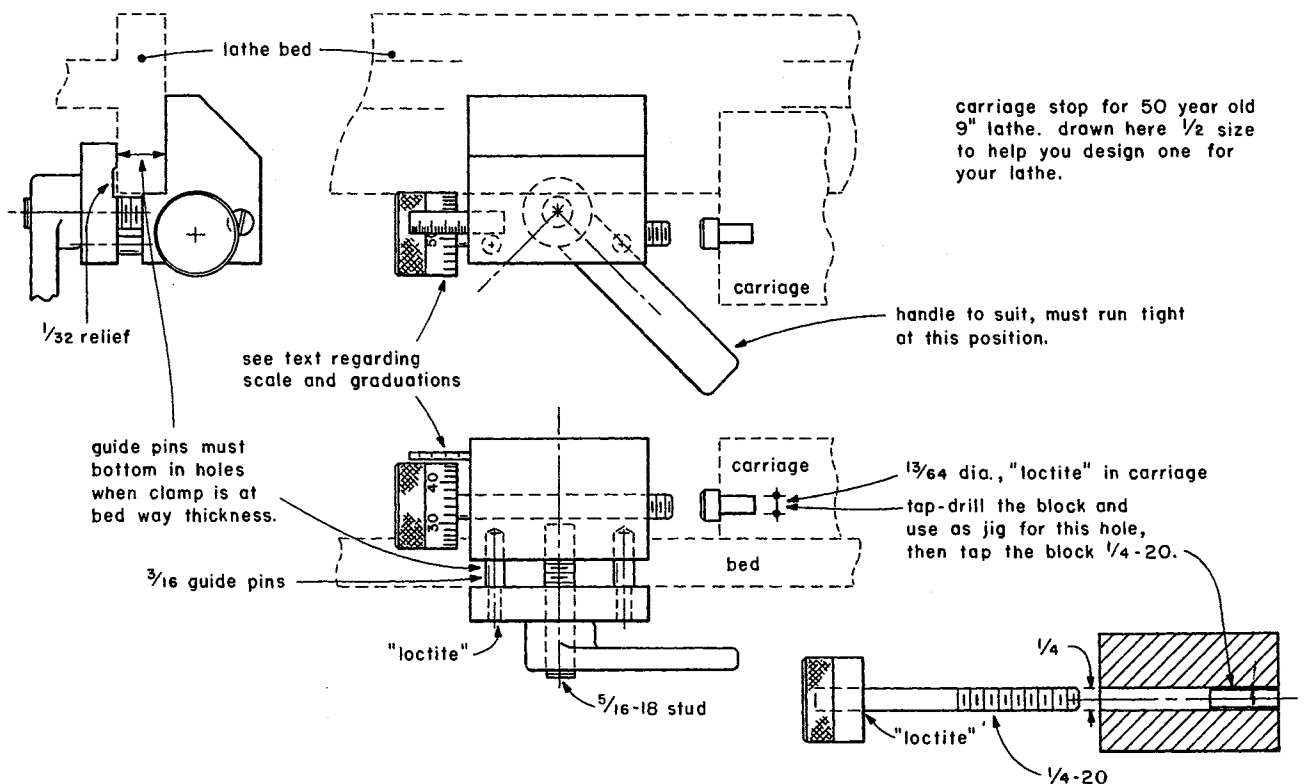
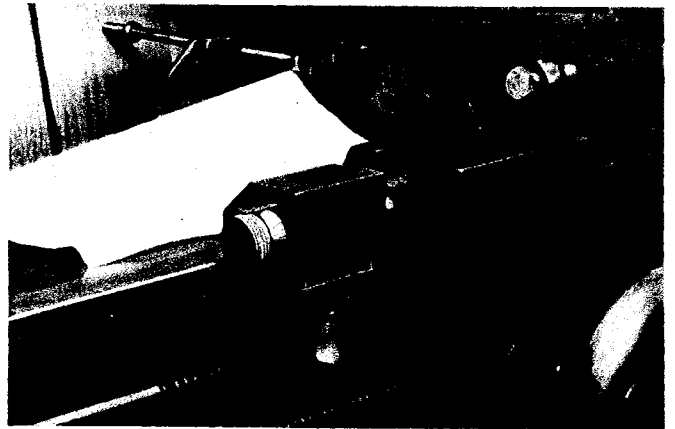

Cross-Slide Milling Attachment

I have a 12" quick change lathe that used this cross-slide milling attachment. Also, a simple 9" lathe purchased some fifty years ago was standing idle so the above attachment was permanently adapted to it.

The heavy angle block was salvaged from a scrap drill jig. It required a bit of shimming and fitting to mount the

milling slide squarely. The cone-shaped anchor for the lathe compound was attached to the bottom of the heavy angle block. This allows the unit to be swiveled the same as the compound did.

The critical part is squareness. When you are done, the indicator must show zero in all directions of

travel on the cross-slide.

Also, two stops were added (one shows clearly in the center foreground of the photo) so the unit can be turned 90° and the mounting face is either exactly parallel with the lathe bed or at 90° to the bed. Of course, the vertical travel must be square with the bed at all times.

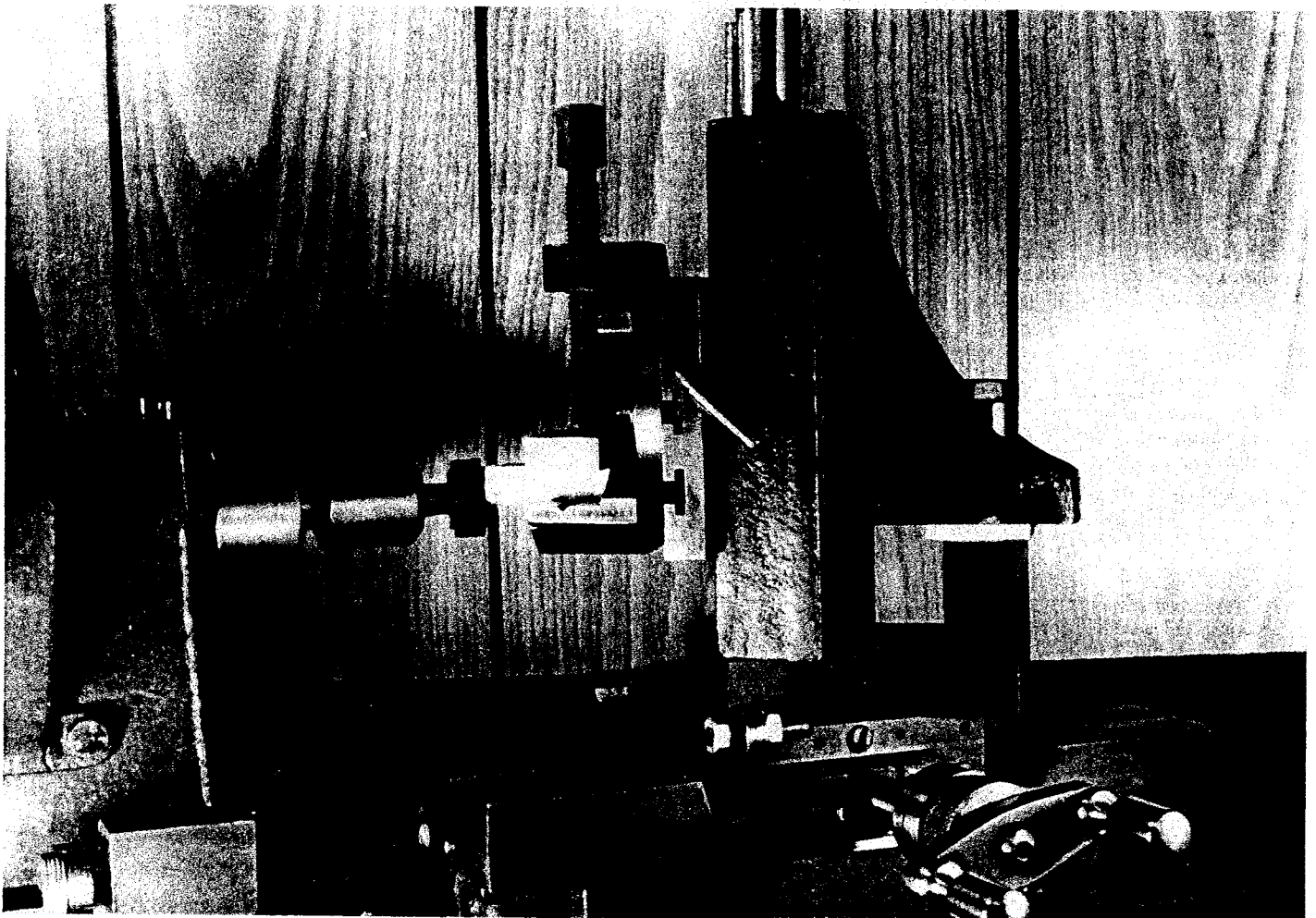

Rule **F**
Safety First

Scribing Bolt Circles

For accuracy and concentricity, it is worthwhile to scribe a bolt circle while the workpiece still is mounted in the lathe. With a tool made as shown from a standard blank — or even from a broken drill or tap — both locating and scribing the bolt circle becomes a simple matter. There is no pressure on this tool, so it is not necessary for it to be very strong.

In use, first approximate the location of the circle on the workpiece and spin a band of layout dye on the face. Measure the O.D. of the piece with a micrometer and subtract the bolt circle diameter from it. Divide the remainder by two. This will be the amount you feed in when locating the bolt circle. Set the tool bit on the lathe spindle centerline height and *tangent* to the O.D. as shown. This is important. The side of the sharp tip must touch the surface.

Use a cigarette paper to set the bit. Cigarette paper is .001" thick. Very, very slowly, feed in while constantly moving the paper between the bit and the workpiece. The instant the paper catches and will not move, you are .001" or less from the surface. Without disturbing the crossfeed, set the collar at zero.

Run the carriage to the right until the bit is off the workpiece. Turn the crossfeed in by the amount indicated by our earlier measurements and calculations. Now, again — very, very slowly — run the carriage toward the workpiece until an almost invisible chip is formed when the work is rotated by hand. A handy thing to determine this is a headband binocular magnifier. Rotate the work by hand until the full circle is made. Microscopically, one side of this scratch is square with the face and the other at an angle. When using a sharp divider in this groove, the error will be very small, plenty good for a bolt circle.

If you have an indexing headstock, it will be easy to scribe the centers of the holes. In case you do not have an indexing spindle, it will be necessary to pace off the desired number of spaces. One simple fact that helps is:

the radius of any circle will pace off exactly six equal spaces on *that* circle. This enables you to lay out either three or six accurate spaces.

Also, once you have the six spaces, you can scribe a line through two opposite marks and obtain an accurate line through the center of the work. With some simple geometry and a pair of dividers, four or eight

spaces are easy to get from this centerline. Outside of two, three, four, six and eight, the spacing will have to be trial and error with dividers. Handbooks giving chordal distances for various numbers of holes will help in getting an initial divider setting.

Finish your bolt circle by prick-punching, then center-punching and drilling.

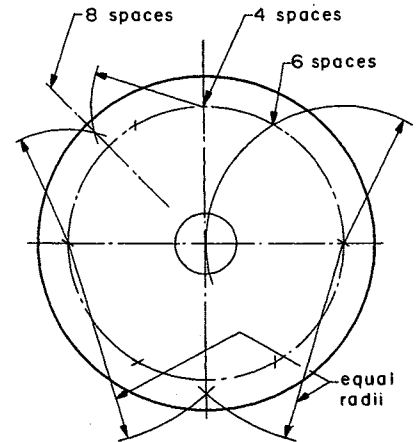
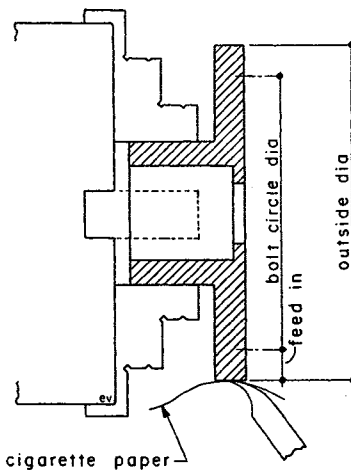

EXAMPLE

outside dia	4.008
bolt circle	-3.250
	<hr/>
	.758
divide	+ 2
feed in	.379

BOLT CIRCLE LAYOUT

SETTING SCRIBING TOOL

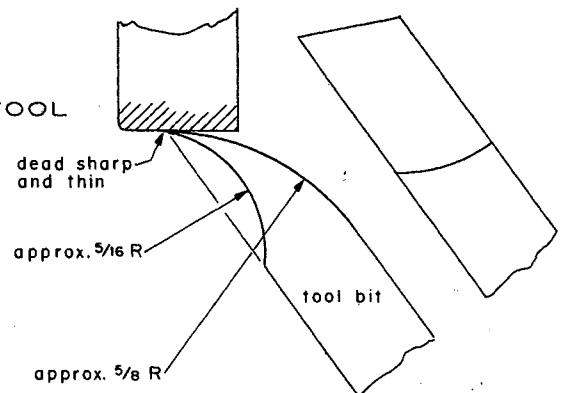

TOOL FORM

Parallel Clamp Vise

There isn't anything new or sensational about these vises, but they have proven quite handy around my shop. They are the result of a need for holding thin material such as bronze spring stock when making electro-mechanical parts by hand in the model shop.

The standard vise is too coarse for making tiny parts requiring fine filing and shaping. These clamp vises provide solid working conditions and fair knuckle clearance when using needle files, etc. The clearances in these vises are small, so there is good jaw alignment and yet allowance for a bit of taper in the stock. The large wheels make it easy to tighten the jaws. A grip as small as 1/32" can be made on narrow stock. The work is a few inches nearer eye level, making work more comfortable and they should be handy when making eccentric straps, etc., from thin, flat stock. They are fine companion pieces to a finger-plate vise and have been used many times in that combination. All five of the vises shown in this article have been made and all seemed to adapt to some job or another.

No fine details are given since you will, no doubt, adapt material from your own stock . . . and you may have some ideas of your own to incorporate.

STYLE A is probably the best all-around for general purposes in a model shop.

STYLE B can take irregular pieces with bends and projections. It is limited to thin material only. It also takes the most pressure to tighten. Holes were added to the knob so a pin could be used for added leverage.

The two jaws were clamped tightly together, well aligned, and drilled 7/64" for the 1/8" pin.

STYLE C is obviously for tiny parts or parts with very little flat surface to grip.

STYLE D is husky and will work well for larger pieces and for bending thin stock.

STYLE E holds a limber piece on two sides while shaping a center opening. It is, perhaps, a bit more limited and justified only if you see a future use for it.

Note that **A**, **C**, **D** and **E** all have the tapped holes in the short member. The screws are just a close free fit in the long pieces. A reasonably close fit keeps the jaws in alignment. All the springs are salvage from the odds-and-ends department.

C and **E** are hex socket-head screws: the knob is bored for a drive fit on the screw head.

Here are some simple tools that will make your shop work easier. Each vise in this group of five has a specific use and performs well in that task. Make a set of these clamps for your shop and enjoy the convenience that adequate tooling can provide for you.

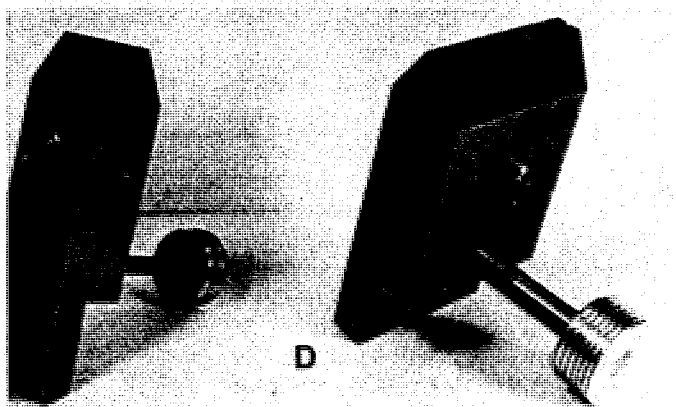
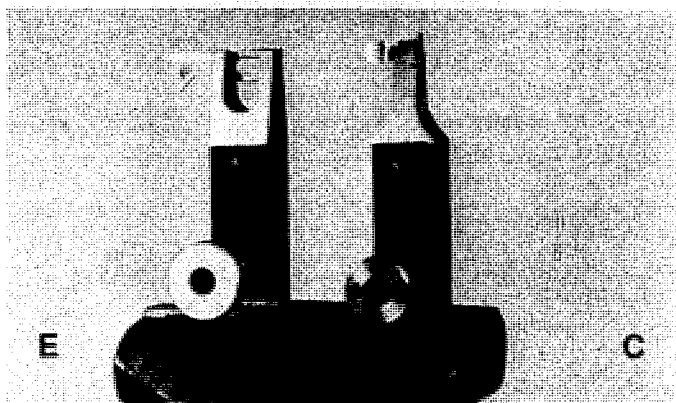
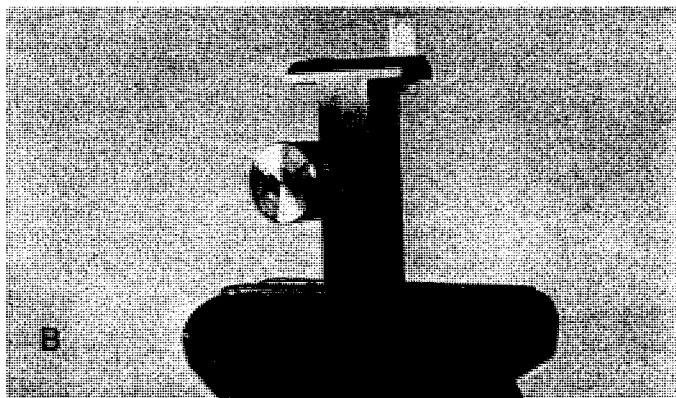
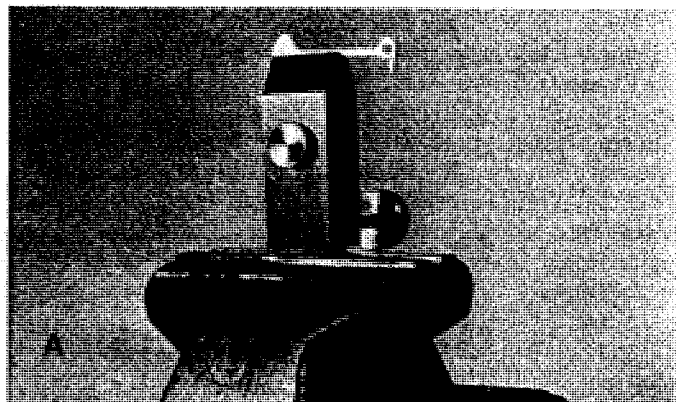

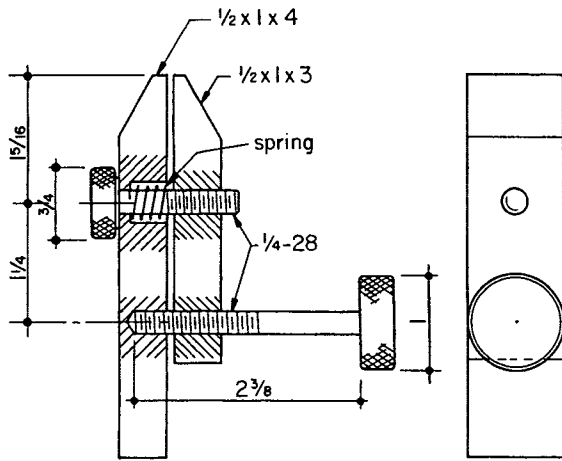

VISE A

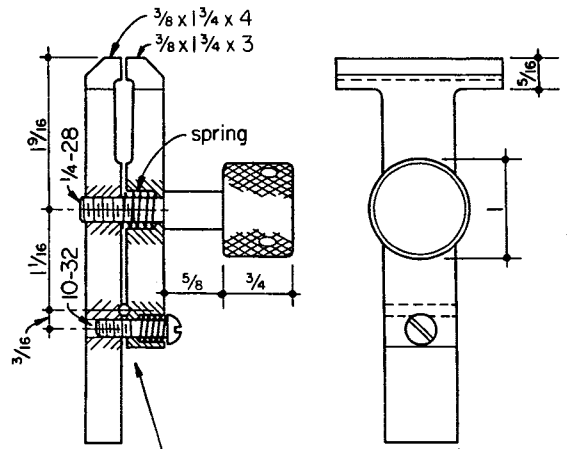

VISE B

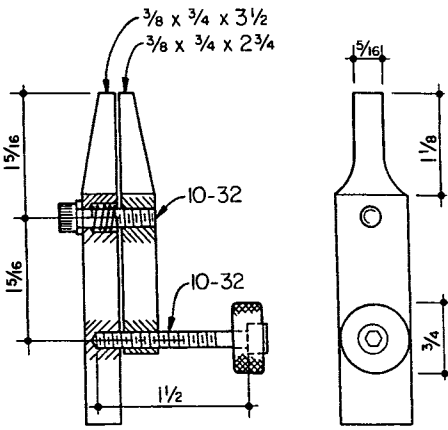
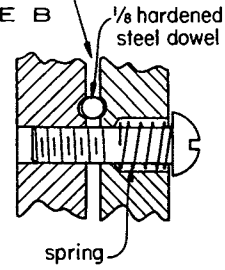

VISE C

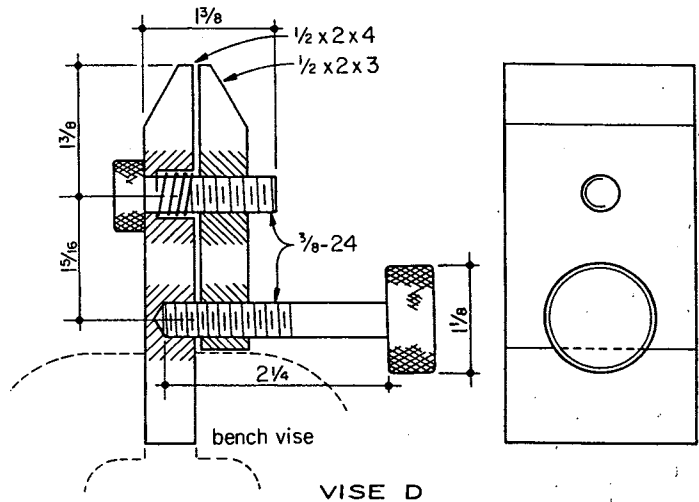

VISE D

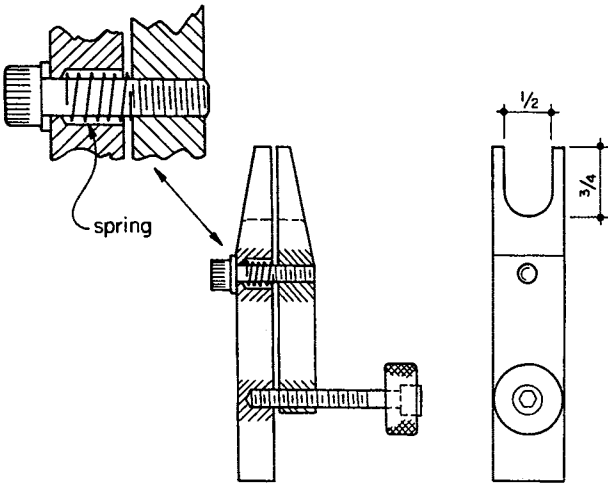

VISE E

PARALLEL CLAMP VISE

Offset Tailstock Center

Taper turning in the lathe is best done with a regular taper attachment. If you don't have one, the tailstock is offset to produce a taper. I agree with Charles Darling when he described a new milling machine he was trying out. The machine had a swivel head and the job of getting it square with the table after being tilted was a bit of a problem. He said, "I got it perfectly square and I believe I'll leave it that way." That is the way I feel about offsetting the tailstock of my lathe. Anyone who disturbs that tailstock is going to be sent to Siberia!

This simple center is an attachment for the drill pad. It involves common machine shop practice and only a few important details will be mentioned. The 60° **CENTER** must

be tool steel, hardened. Make the **BOLT A** a close fit in the **BAR**. The Exaggerated sketch **B** shows the relation of the Center to the center hole. As you see, there is only line contact on a steep taper. The slower the taper, the better the condition at the center. So take it easy and keep the center well coated with high-pressure grease. Keep the Offset Center at the same height as the Live Center and not too much pressure on the work piece.

Setting up the Center is a bit of a chore since there are no dials to read. You must calculate the amount to move the Center. Bring it up to the Live Center and measure across for a starter. Say you want 1/8" taper in 6" on a connecting rod. One-half of the

taper is 1/16". Since, in the example shown, there is 1" added to each end, then the offset must be 1/3" greater than 1/16".

Start out with an offset a bit more than required and make a trial cut. The taper will run out before reaching the 6" distance. Tunk the bar over a bit and repeat, keeping track of the small diameter each time so you won't go undersize.

Adding the two 10-32 screws will help make fine adjustments. One turn of a 10-32 screw moves the Center 1/32". One-half turn moves 1/64" and one-fourth turn moves .008", so you can have an idea of how much you move it. Use this general layout and make one to suit your lathe and use your own ideas for such a tool.

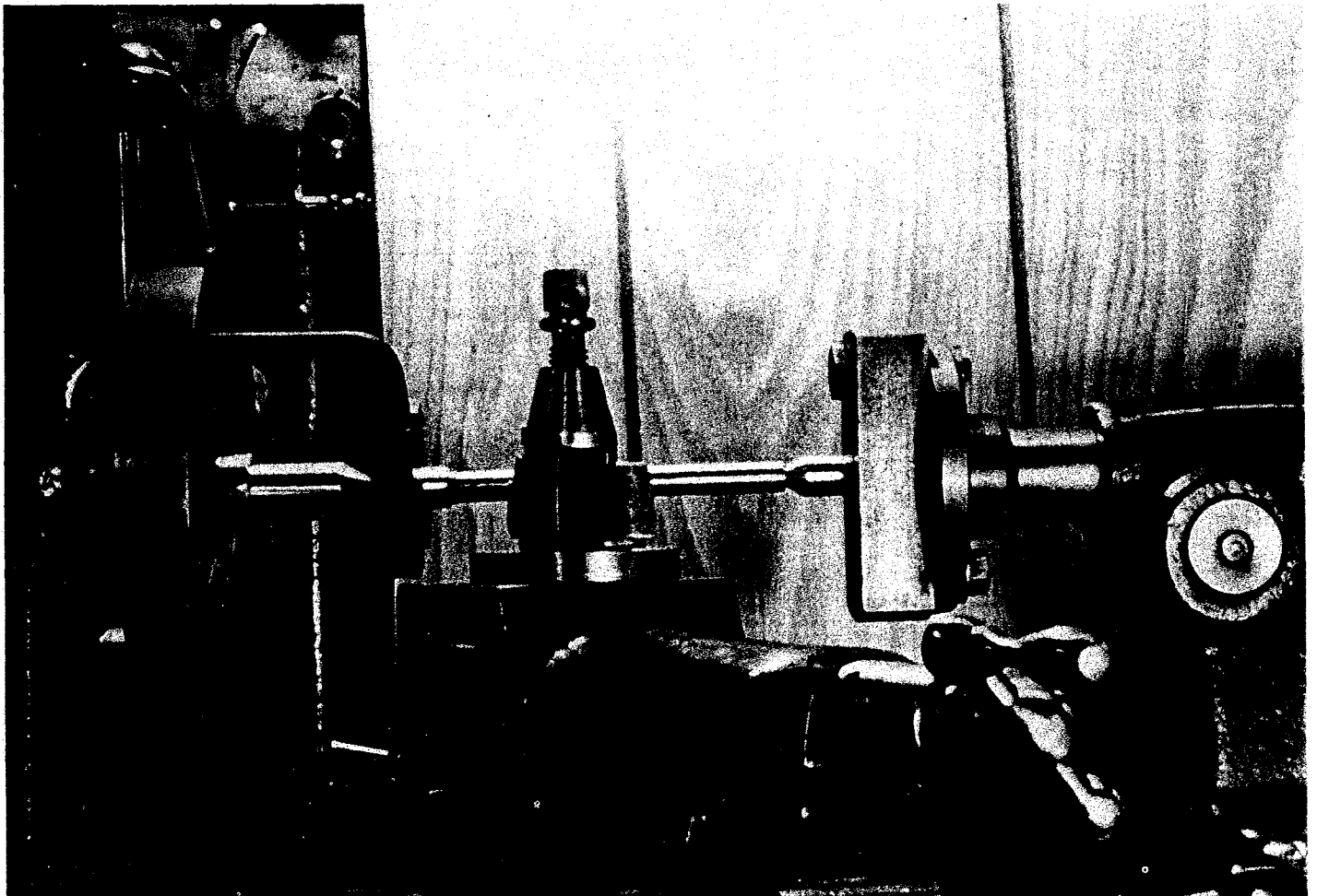

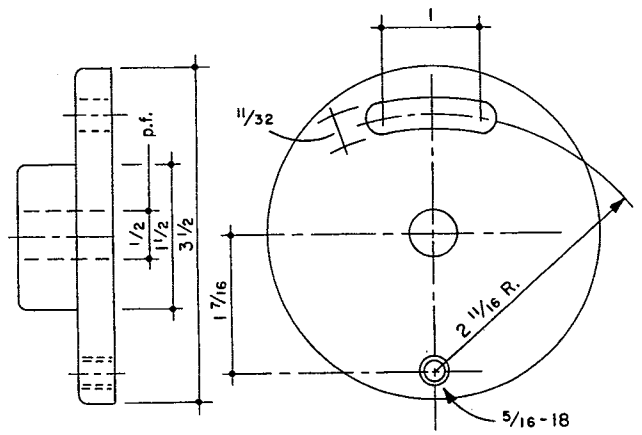
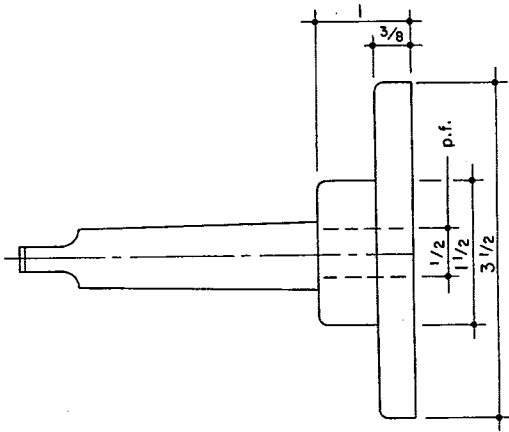

TAILSTOCK DRILL PAD

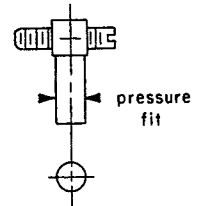
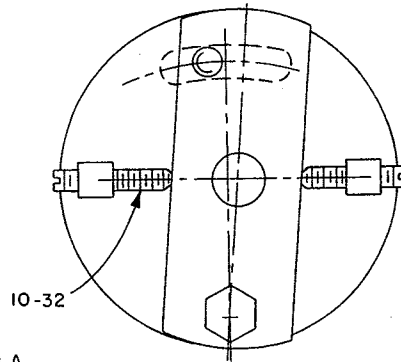
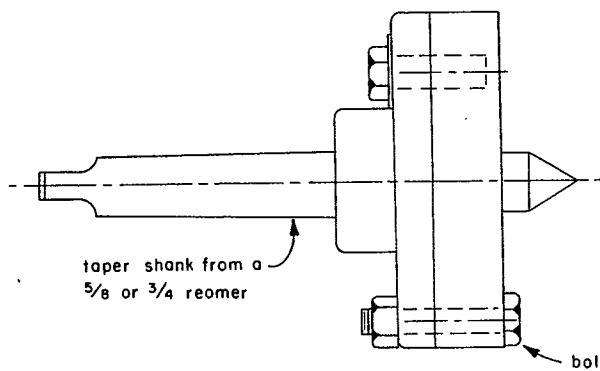

ADJUSTING SCREWS

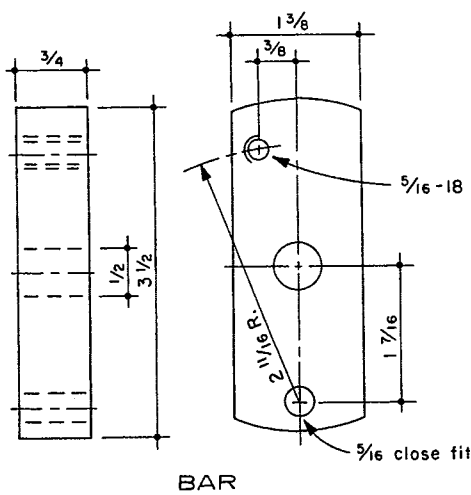

BAR

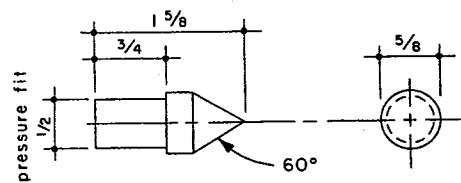

CENTER
Tool Steel, Harden

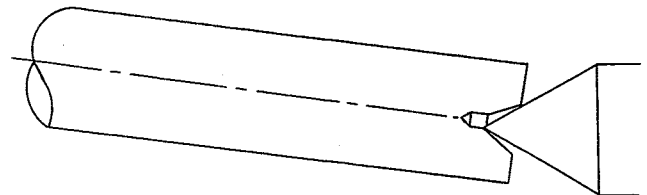

SKETCH B

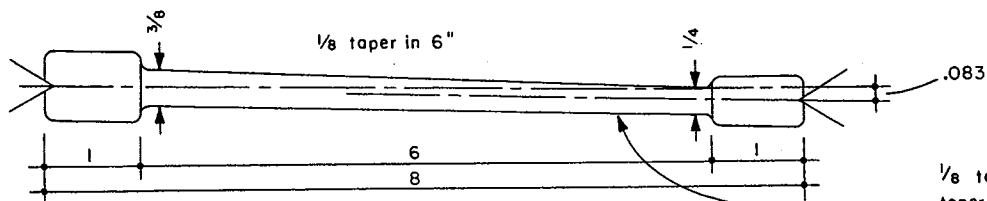

EXAMPLE

1/8 taper in 6" = 1/16 offset
taper at 8" = 9/6 or 1 1/3 x 1/16
.062 x 1.333 = .083 offset

OFFSET TAILSTOCK CENTER

EV/rbo

Handy Scale

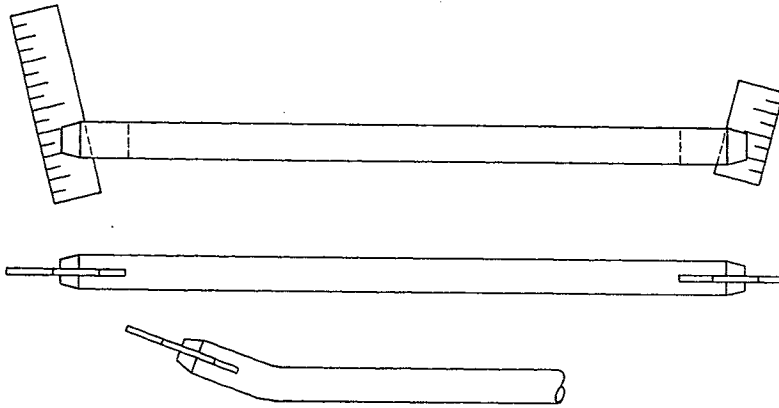

If you have a narrow scale, badly worn or broken, cut (as accurately as you can) a one-inch and a half-inch piece on the 1" and the 1/2" marks respectively.

Check these pieces with a good scale, making sure that the marks coincide when the ends are held against a flat surface.

Mill slots in the ends of a 4" piece of 3/16" round stock, just a shade over the thickness of the pieces of the scale.

Slightly pinch these ends together so the scale pieces have to be forced into the slots.

You now have a scale to reach in where a regular scale cannot go.

Make a second tool. Repeat the steps except bend the 3/16" rod at a slight angle. On some jobs, this makes the scale easier to read.

This is just the beginning!

While this may be the end of the book, it is really just the beginning of years of enjoyment in your shop. If the ideas presented here result in the enjoyment to be achieved in actually building a working object, this book has served a good purpose. If, however, it provides food for thought that helps you analyse a problem and arrive at a satisfactory solution, then you have received the full value of this work.

Keep in mind, though, that the Author and the publisher cannot be re-

sponsible for the accuracy of the plans, drawings, technical data or information contained in this book, and that the reader makes use of such at his own risk. None of the statements made or information contained herein shall create any warranty, expressed or implied, nor that any of the various devices, plans, drawings, mechanical systems or data shall be fit or useful for any particular purpose. The statements contained are informational only and not made or given as a warranty of the data in any way. The reader shall be

solely responsible for determining the accuracy and adequacy of the data for any and all uses to which the reader shall apply the data.

Please keep the safety suggestions throughout this book foremost in your mind as you work with your machine and hand tools. Overconfidence in working with machinery can create a dangerous situation.

Work carefully and thoughtfully and your hobby activity can be most enjoyable and rewarding for years to come.